

Haier

MRV II

Apr. 2006

CONTENTS

MRVII Dual-variation multi-combination system

1. Product introduction	
1.1 MRV II general information and features	02
2. Product design	
2.1 Model selection	07
2.2 Performance curves	22
2.3 Noise level	24
3. Installation instruction	
3.1 Outdoor installation	30
3.2 Indoor installation	49
3.3 Circuit diagram	84
3.4 Electric installation	96
4. Debugging	
4.1 Trial operation and the performance	101
4.2 Control function	116
4.3 Management system H-CACS	132
5. Maintenance	
5.1 Trouble diagnose	159
5.2 Sensor characteristic	180
APPENDIX	184

MRV II Dual-variation multi-combination system

MRVII Dual-variation multi-combination system

	Master unit	Slave unit	
Outdoor	AU96NMTAHA AU78NMTAHA 	AU78NMTAHA AU96NMTAHA 	AV16NMTAHA AV18NMTAHA AV20NMTAHA 
		AV24NMTAHA AV26NMTAHA AV28NMTAHA AV30NMTAHA 	AV32NMTAHA AV34NMTAHA AV36NMTAHA AV38NMTAHA AV40NMTAHA 
Indoor	AD072~242MLAHA 	AB072~162MCAHA 	AB182~482MCAHA 
	AD322~482MMAHA 	AS072~182MCAHA 	



Product introduction

1.1 MRV II general information and features



1.1 MRV II general information and features

MRV II can be used in a large combination with multiple outdoor units; it is only one system and is the second generation of C-MRV. Major features are energy saving, intelligent control and precise temperature control. Adopts power source of 3-phase, 380V, 50Hz; control the refrigerant flow by the electronic expansion valve (EEV); collects the data by the pressure sensor and temperature sensor to adjust the compressor capacity; it comprises the master unit and the slave unit, and the former adopts one inverter compressor, while the latter adopts one variable-capacity compressor; realize the capacity combination from 8HP to 40HP; includes the oil equalization, oil return, refrigerant return, refrigerant spray, unloading assistant control.

1.1.1 Products code explanation

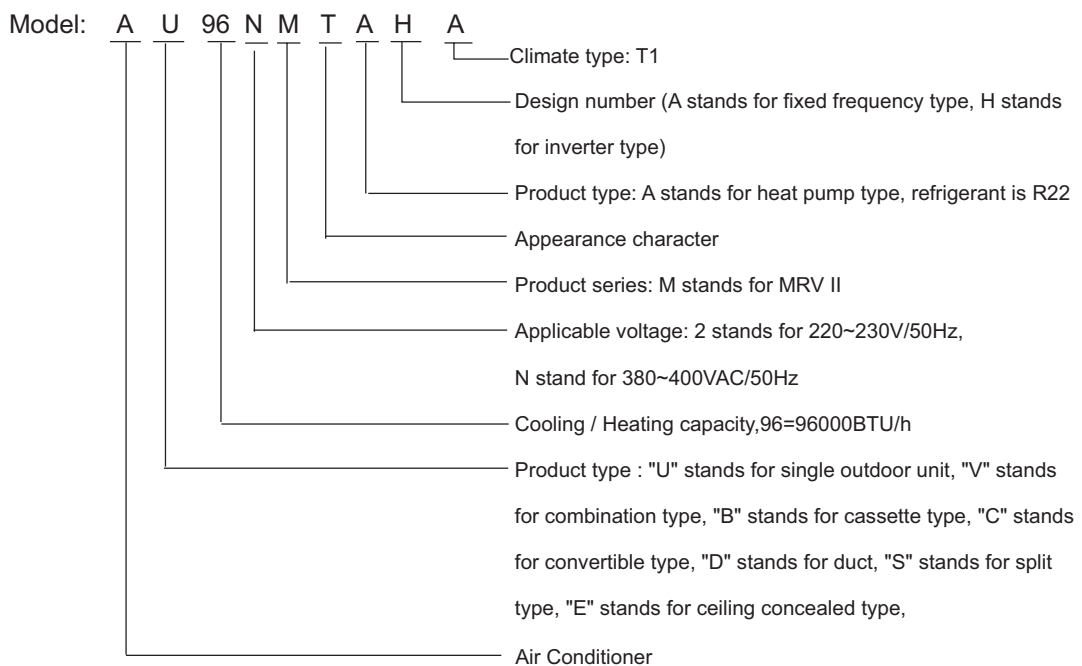

1.1.2 Indoor models

Capacity(HP)		072 (0.8)	092 (1.0)	122 (1.25)	142 (1.5)	162 (1.7)	182 (2.0)	242 (2.5)	282 (3.0)	322 (3.2)	382 (4.0)	482 (5.0)
Ceiling concealed type	AD- *MLAHA	∩æ	∩æ	∩æ	∩æ	∩æ	∩æ	∩æ				
Cassette type	AB- *MCAHA	∩æ	∩æ	∩æ	∩æ	∩æ	∩æ	∩æ	∩æ	∩æ	∩æ	∩æ
Duct type	AD- *MMAHA									∩æ	∩æ	∩æ
Wall mounted	AS- *MCAHA	∩æ	∩æ	∩æ	∩æ	∩æ						



1.1.3 Combination of Outdoor unit

Outdoor unit		QTY of Outdoor unit					Indoor unit	
Capacity (100W)	HP	AU78NMTAHA	AU78NMTAAA	AU96NMTAHA	AU96NMTAAA	Total QTY	Total capacity (100W)	QTY
226	8	1	0	0	0	1	113~294	1~13
280	10	0	1	0	0	1	140~364	1~16
452	16	1	0	1	0	2	226~588	2~18
506	18	0	1	1	0	2	253~658	2~18
560	20	0	1	0	1	2	280~728	2~20
678	24	1	0	2	0	3	339~881	3~24
732	26	0	1	2	0	3	366~951	3~26
786	28	0	1	1	1	3	393~1022	3~28
840	30	0	1	0	2	3	420~1092	3~30
904	32	1	0	3	0	4	452~1175	4~32
958	34	0	1	3	0	4	479~1245	4~34
1012	36	0	1	2	1	4	506~1315	4~36
1066	38	0	1	1	2	4	533~1386	4~38
1120	40	0	1	0	3	4	560~1456	4~40

1.1.4 Gather pipe assembly(optional)





Total capacity of outdoor unit(100W)	Model
452, 506, 560	HZG-20
678, 732, 786, 840	HZG-30
904, 958, 1012, 1066, 1120	HZG-40

1.1.5 Branch pipe(optional)

Total capacity of indoor unit(100W)	Model
Less than 101	FQG-B120
More than 101 but less than 180	FQG-B180
More than 180 but less than 370	FQG-B370
More than 370 but less than 700	FQG-B700
More than 700 but less than 1100	FQG-B1100
More than 1100	FQG-B1460

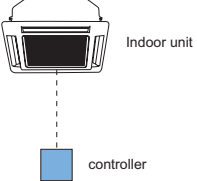

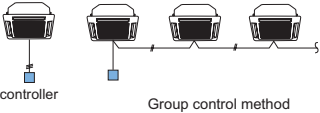
1.1.6 Controllers

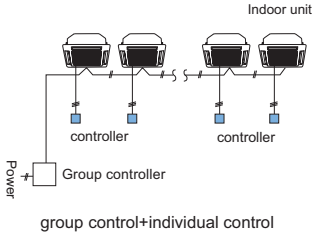
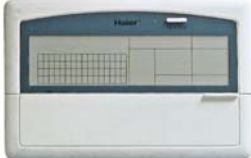
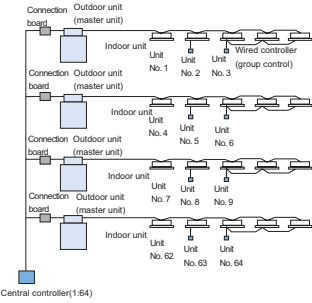
Remote controller	Function	Illustration
 <p>YR-H39</p>	<ul style="list-style-type: none"> <input type="checkbox"/> All the standard functions 	 <p>Indoor unit controller</p>
Wired controller	Function	Illustration
 <p>YR-E12</p>	<ul style="list-style-type: none"> <input type="checkbox"/> Can control at most 16 indoor units synchronously <input type="checkbox"/> A indoor unit can connect with 2 standard(simple) controllers (Master/Slave control) <input type="checkbox"/> Timing function 	 <p>controller Group control method</p>
Group controller(1:16)	Function	Illustration
 <p>YR-E12</p>	<ul style="list-style-type: none"> <input type="checkbox"/> Control 16 groups indoor units separately and display state of each group; <input type="checkbox"/> ON/OFF synchronously function can control all the indoor units run/stop at the same time. Can realize the following mode when combined with the standard controller: <ol style="list-style-type: none"> 1. The latter command between group controller and the standard controller is in priority. 2. Group controller can set the central mode to control all indoor units centrally, and the standard controller only can set ON/OFF mode. 3. Group controller can be in LOCK mode 	 <p>Indoor unit controller Group controller group control+individual control</p>
Central controller(1:64)	Function	Illustration
 <p>ICR01</p>	<ul style="list-style-type: none"> <input type="checkbox"/> Can monitor max.64 groups of indoor unit state: running mode, fan speed, set temp., swing and vent. etc, also will display indoor filter icon; can set below three modes: the later entering indoor in priority, central control and lock; <input type="checkbox"/> Can monitor indoor failure and save the failure to be checked. <input type="checkbox"/> Receive the external signal such as the fire alarm, make the interconnect control; <input type="checkbox"/> Receive the external timing signal to make TIMER ON/OFF control. 	 <p>Connection Outdoor unit (master unit) board Indoor unit Unit No. 1 Unit No. 2 Unit No. 3 Wired controller (group control) Connection Outdoor unit (master unit) board Indoor unit Unit No. 4 Unit No. 5 Unit No. 6 Connection Outdoor unit (master unit) board Indoor unit Unit No. 7 Unit No. 8 Unit No. 9 Connection Outdoor unit (master unit) board Indoor unit Unit No. 62 Unit No. 63 Unit No. 64 Central controller(1:64)</p>



1.1.7 features

- (1) Inverter technology and variable capacity technology
- (2) 4-way air return heat-exchange technology
- (3) Priority control for indoor unit
- (4) Precise temperature control

1.1.8 Functions and characteristics

- (1) High efficiency and energy saving

According to required indoor capacity, the master unit is inverter type and the slave units can run with half or full load and is able to regulate running state of each outdoor unit automatically. Greatly improve efficiency at full capacity range, realizes high efficiency and energy-saving due to the perfect outdoor heat exchanger.

- (2) Long piping design

Piping length between the indoor units and outdoor units in one system can extend up to 100m; the difference in height can be up to 50m and the height difference between indoor units is 20m.

- (3) Realizing capacity compensation by PID electronic expansion valve control

According to the room cooling load of buildings, the system finely controls the indoor unit capacity by using PID electronic expansion valve control, avoids refrigerant deflection and realizes comfortable air conditioning space.

- (4) Precise control to ensure the comfortable and steady environment

The system is very stable because of the use of high and low pressure sensors. Assistant control systems (such as oil equalization, oil return, refrigerant reclaim, refrigerant spray and unloading etc.) are adopted to ensure the compressor operates steadily, avoids efficiency drop due to the frequency reduction and makes sure the system run more stably and precisely.

- (5) Easy Maintenance

All running parameters may collect from digital LEDs and rotary switches on PCB. Many test modes or backup running modes are possible for easier test running and troubleshooting.



Product design

2.1 Model selection

2.2 Performance curves



2.1 Model selection

2.1.1 Usage range

Refrigerant pipe length (one way)		MAX. 125m
Distance from outdoor to the first branch		MAX. 70m
Piping length after the first branch		MAX. 50m
Piping length between outdoor units		Within 5m after gather branch
Height difference between IU&OU	Outdoor is higher	MAX. 50m
	Indoor is higher	MAX. 40m
Height difference between outdoor units(the same system)		In horizon
Height difference between indoor units		MAX. 20m
Voltage	Voltage range	rated voltage \pm 10%
	Voltage decrease when starting	rated voltage \pm 15%
	Unbalance among phases	rated voltage \pm 3%

Note: Total capacity of the running indoor units should not be more than the nominal capacity of outdoor unit.

2.1.2 Piping length between outdoor units

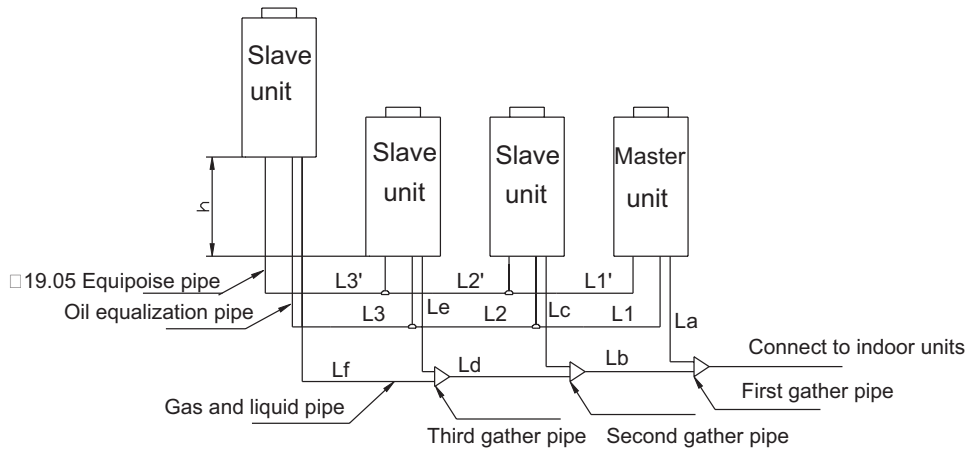

Gas and liquid pipe: La+Lb; 5m, Lb+Lc; 5m, Lb+Ld+Le; 5m, Lb+Ld+Lf; 5m,

Oil equalization pipe: L1; 5m, L2; 5m, L3; 5m,

Equipoise pipe: L1'; 5m, L2'; 5m, L3'; 5m

Height difference between outdoor units: 0m



2.1.3 Refrigerant piping length and Height difference between indoor&outdoor units

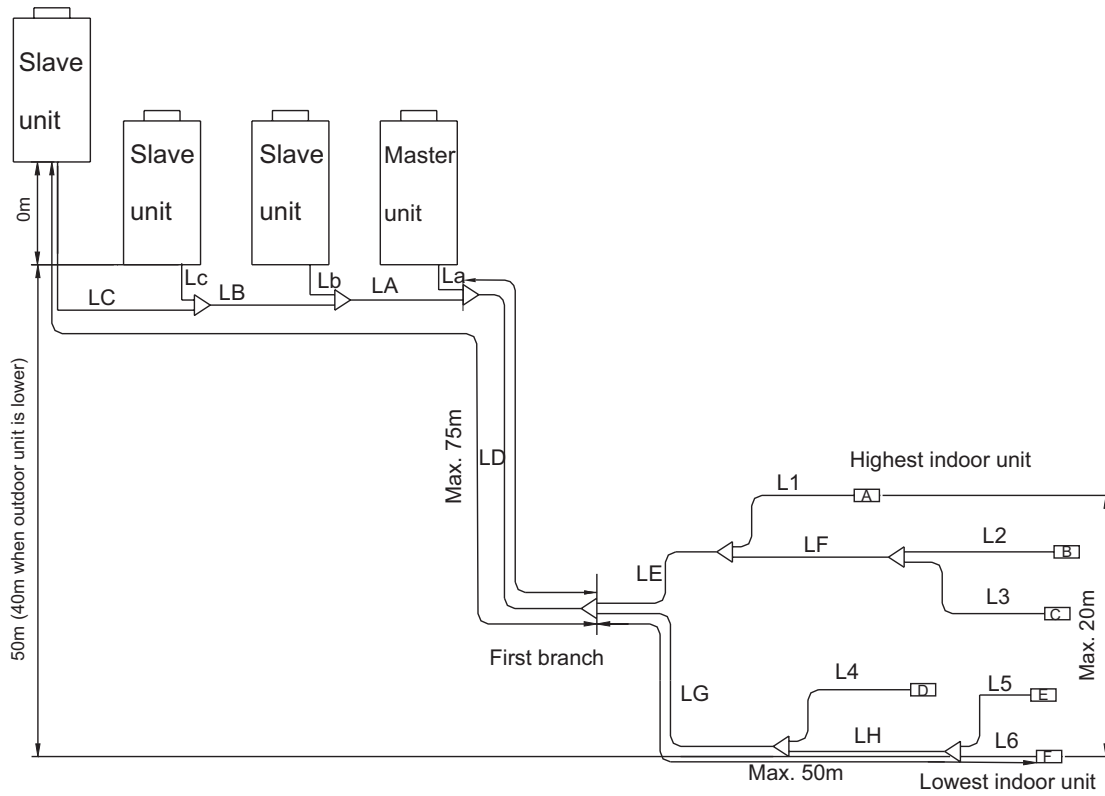

	Max. piping(m)	piping
Total piping length	250	$L_a+L_b+L_c+L_A+L_B+L_C+L_D+L_E+L_F+L_G+L_H+L_1+L_2+L_3+L_4+L_5+L_6$
Longest pipe length	Actual(100)	$L_A+L_B+L_C+L_D+L_G+L_H+L_6$
	Equivalent(125)	
Max. piping length after the first branch	50	$L_G+L_H+L_6$
Main piping length	70	L_D
Height difference between indoor units	20	" " " " " "
Height difference between outdoor units	0	" " " " " "



2.1.4 Refrigerant diagram

(1) Master unit: AU78NMTAHA, AU96NMTAHA

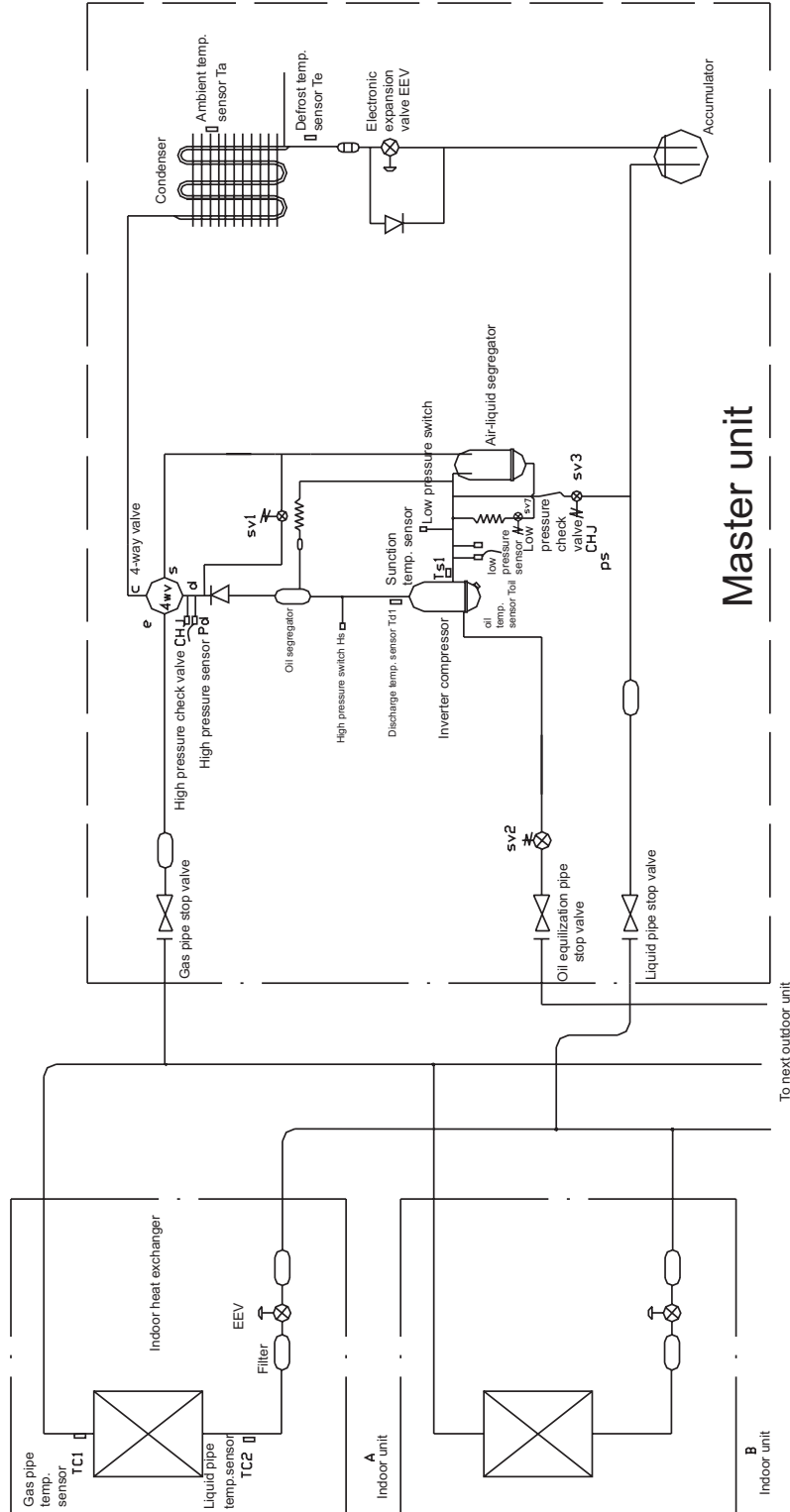



(2) Slave units: AU78NMTAAA, AU96NMTAAA

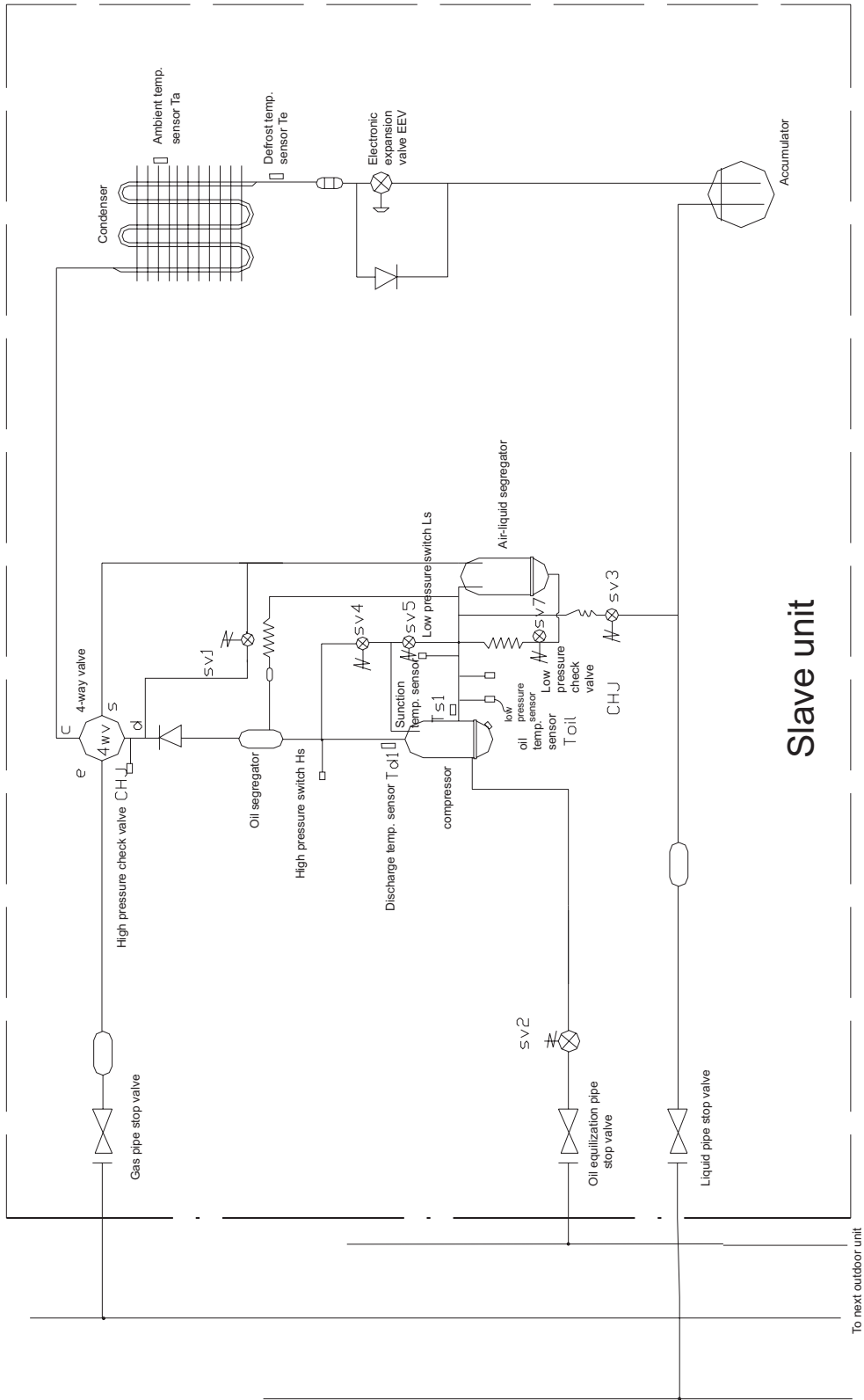



2.1.5 Main parts

(1) Master unit

Part name	Sign	Function	Data
Compressor	MC	capacity control, meet indoor load request by adjusting the frequency	resistor of 3-phase coil:0.481 Ω , $\epsilon\epsilon\epsilon 20\Omega$
Pressure switch	Hs	High pressure protection	3.3Mpa, OFF
	Ls	Low pressure protection	0.05 Mpa,OFF
Pressure sensor	Pd	in heating,compressor frequency correction,abnormal pressure protection	PS8040A150NH4-H
	Ps	in heating,compressor frequency correction,EEV overheat control,abnormal pressure protection	PS8040A150NH4-L
Electronic expansion valve	EEV	in heating,refrigerant flow control	full pulse:2000 10TON
Solenoid valve	SV1	reduce high/low pressure drop on compressor startup; high/low pressure protection; light load control	AC220V, open when power is on; close when power is off
	SV2	oil equalization control	
	SV3	discharging temp. and oil temp. control	
Oil return valve	SV7	used to control oil return of gas-liquid segregator	
4-way valve	4WV	change over between cooling and heating	AC220V,electrified in heating; not electrified in cooling or defrosting
Temp. sensor	Toil	check refrigerant oil temp. at compressor bottom	R(25 Ω)=10K
	Te	check frost condition of outdoor heat exchanger	B(25/50 Ω)=3700K
	Td	Detect the discharge temp. of compressor	R(80 Ω)=50K B(25/80 Ω)=4450K
	Ts	Detect the suction temp. of compressor, EEV open control	R(25 Ω)=10K
	Ta	detect ambient temp.,set primary setting for fan speed and EEV open angle	B(25/50 Ω)=3700K
Heater	CH1	used to heat liquid refrigerant in gas-liquid segregator	40W, 220V
	CH2	used to heat liquid refrigerant in compressor	48W*2, 220V
Pressure equalization valve	SV8	used to equalize low pressure of master and slave unit	AC220V, open when power is on; close when power is off



(2) Slave unit

Part name	Sign	Function	Data
Compressor	MC	capacity control, meet indoor load request by using solenoid valve SV4 and SV5 to adjust the capacity	resistor of 3-phase coil : 1 . 197 f , 220 V
Pressure switch	Hs	High pressure protection	3.3Mpa, OFF
	Ls	Low pressure protection	0.05 Mpa, OFF
Pressure sensor	Ps	check compressor low pressure, in heating EEV overheat control, pressure switch control	PS8040A150NH4-L
Electronic expansion valve	EEV	refrigerant flow control	10TON
Solenoid valve	SV1	reduce high/low pressure drop on compressor startup; high/low pressure protection; light load control	AC220V, open when power is on; close when power is off
	SV2	oil equalization control	
	SV3	Control discharge temp. and oil temp.	
	SV4	Control the capacity of compressor	
	SV5		
Oil return valve	SV7	Control oil return of gas-liquid separator	
4-way valve	4WV	Cooling, heating conversion	AC220V, electrified in heating; not electrified in cooling or defrosting
Temp. sensor	Toil	check refrigerant oil temp. at compressor bottom	R(25 ;)=10K
	Te	check frost condition of outdoor heat exchanger	B(25/50 ;)=3700K
	Td	Detect the discharge temp. of compressor	R(80 ;) =50K B(25/80 ;)=4450K
	Ts	detect compressor suction temp., EEV open angle	R(25 ;) =10K
	Ta	detect ambient temp., set primary setting for fan speed and EEV open angle	B(25/50 ;)=3700K
Heater	CH1	used to heat liquid refrigerant in gas-liquid separator	40W, 220V
	CH2	used to heat liquid refrigerant in compressor	48W*2, 220V

(3) Indoor unit

Part name	Sign	Function	Data
Electronic expansion valve	EEV	in heating, refrigerant flow control	CAM-BD22FKS-1
			CAM-BD24FKS-1
			HAM-BD30FKS-1
Temp. sensor	TC1	Detect gas pipe temp.	R(25 ;)=10K
	TC2	Detect liquid pipe temp.	B(25/50 ;)=3700K
	Ta1	Detect indoor ambient temp.	R(25 ;)=23K
	Ta2	Detect temp. of wired controller	B(25/50 ;)=4200K



6. Specifications

(1) Outdoor unit

Equivalent HP		10	10	8	8	
Model		AU96NMTAHA	AU96NMTAAA	AU78NMTAHA	AU78NMTAAA	
Combination mode		**	For combination	**	For combination	
Nominal cooling capacity(KW)		28.0	28.0	22.6	22.6	
Nominal heating capacity(KW)		31.5	31.5	25.0	25.0	
Heating capacity at low temp.(KW)		24.3	24.3	19.5	19.5	
Power source		3N~, 380V, 50Hz				
Electrical characteristics	Cooling	Operating/Max. current(A)	16.8/22.1	16.1/18.3	13.0/18.7	12.5/16.7
		Operating/Max. consumption(kw)	9.85/13.5	9.8/11.8	8.0/11.5	7.5/10.8
	Heating	Operating/Max. current(A)	16.5/20.8	14.8/16.6	11.5/17.6	11.5/16.3
		Operating/Max. consumption(kw)	9.6/13.0	9.0/10.8	7.0/11.0	7.0/10.5
	Power consumption when heating at low temp.(kw)		9.0	8.5	6.5	6.5
Output power of outdoor motor(KW)		0.35				
Exterior dimensions (mm)		990*750*1700				
Weight (Kg)		235				
Exterior colour		ivory				
Compressor model		scroll				
Outdoor airflow (m3/min)		167				
Refrigerant (R22) charge (Kg)		13.0	10.0	13.0	10.0	
Piping dimension	Gas piping(mm)		F28.58			
	Liquid piping(mm)		F12.7			
	Equipoise/Oil equalization piping(mm)		F19.05/F9.52			
Noise level(dB(A))		58.0	58.0	57.0	57.0	

Equivalent HP		16		18			
Model		AV16NMTAHA		AV18NMTAHA			
Combination mode		AU78NMTAHA	AU78NMTAAA	AU96NMTAHA	AU96NMTAAA		
Nominal cooling capacity(KW)		45.2		50.6			
Nominal heating capacity(KW)		50.0		56.5			
Heating capacity at low temp.(KW)		39.0		43.8			
Power source		3N~, 380V, 50Hz					
Electrical characteristics	Cooling	Operating/Max. current(A)		25.5/35.4		29.3/38.8	
		Operating/Max. consumption(kw)		15.5/22.3		17.35/24.3	
	Heating	Operating/Max. current(A)		23.0/33.9		28.0/37.1	
		Operating/Max. consumption(kw)		14.0/21.5		16.6/23.5	
	Power consumption when heating at low temp.(kw)		13.0		15.5		
Output power of outdoor motor(KW)		0.7(0.35*2)					
Exterior dimensions (mm)		2000*750*1700					
Weight (Kg)		470(235*2)					
Exterior colour		ivory					
Compressor model		scroll					
Outdoor airflow (m3/min)		334(167*2)					
Refrigerant (R22) charge (Kg)		23.0(13.0+10.0)					
Piping dimension	Gas piping(mm)		F38.1(F28.58*2)		F38.1(F28.58*2)		
	Liquid piping(mm)		F15.88(F12.7*2)		F15.88(F12.7*2)		
	Equipoise/Oil equalization piping(mm)		F19.05/F9.52				
Noise level(dB(A))		60		60			



Equivalent HP		20		24		
Model		AV20NMTAHA		AV24NMTAHA		
Combination mode		AU96NMTAHA	AU96NMTAAA	AU78NMTAHA	AU78NMTAAA*2	
Nominal cooling capacity(KW)		56.0		67.8		
Nominal heating capacity(KW)		63.0		75.0		
Heating capacity at low temp.(KW)		48.6		58.5		
Power source		3N~, 380V, 50Hz				
Electrical characteristics	Cooling	Operating/Max. current(A)		32.9/40.4		
		Operating/Max. consumption(kw)		19.65/25.3		
	Heating	Operating/Max. current(A)		31.3/37.4		
		Operating/Max. consumption(kw)		18.6/23.8		
	Power consumption when heating at low temp.(kw)		17.5		19.5	
Output power of outdoor motor(KW)		0.7(0.35*2)		1.05(0.35*3)		
Exterior dimensions (mm)		2000*750*1700		3010*750*1700		
Weight (Kg)		470(235*2)		705(235*3)		
Exterior colour		ivory				
Compressor model		scroll				
Outdoor airflow (m3/min)		334(167*2)		501(167*3)		
Refrigerant (R22) charge (Kg)		23.0(13.0+10.0)		33.0(13.0+10.0*2).7*3)		
Piping dimension	Gas piping(mm)		F38.1(F28.58*2)		F38.1(F28.58*2)	
	Liquid piping(mm)		F19.05(F12.7 *2)		F19.05(F12.7*2)	
	Equipoise/Oil equalization piping(mm)		F19.05/F9.52			
Noise level(dB(A))		60		61		

Equivalent HP		26			28	
Model		AU26NMTAHA			AU28NMTAHA	
Combination mode		AU96NMTAHA	AU78NMTAAA*2	AU96NMTAHA	AU96NMTAAA	AU78NMTAAA
Nominal cooling capacity(KW)		73.2			78.6	
Nominal heating capacity(KW)		81.5			88.0	
Heating capacity at low temp.(KW)		63.3			68.1	
Power source		3N~, 380V, 50Hz				
Electrical characteristics	Cooling	Operating/Max. current(A)			41.8/55.5	
		Operating/Max. consumption(kw)			24.85/35.1	
	Heating	Operating/Max. current(A)			39.5/53.4	
		Operating/Max. consumption(kw)			23.6/34	
	Power consumption when heating at low temp.(kw)		22			24
Output power of outdoor motor(KW)		1.05(0.35*3)			1.05(0.35*3)	
Exterior dimensions (mm)		3010*750*1700			3010*750*1700	
Weight (Kg)		705(235*3)			705(235*3)	
Exterior colour		ivory				
Compressor model		scroll				
Outdoor airflow (m3/min)		501(167*3)				
Refrigerant (R22) charge (Kg)		33.0(13.0+10.0*2) 7*3)				
Piping dimension	Gas piping(mm)		F44.5(F28.58*3)			
	Liquid piping(mm)		F22.22(F12.7*3)			
	Equipoise/Oil equalization piping(mm)		F19.05/F9.52			
Noise level(dB(A))		61			61	



Equivalent HP		30	32	
Model		AV30NMTAHA	AV32NMTAHA	
Combination mode		AU96NMTAHA AU96NMTAAA*2	AU78NMTAHA AU78NMTAAA*3	
Nominal cooling capacity(KW)		84.0	90.4	
Nominal heating capacity(KW)		94.5	100.0	
Heating capacity at low temp.(KW)		72.9	78.0	
Power source		3N~, 380V, 50Hz		
Electrical characteristics	Cooling	Operating/Max. current(A)	49.0/58.7	50.5/68.8
		Operating/Max. consumption(kw)	29.45/37.1	30.5/43.9
	Heating	Operating/Max. current(A)	46.1/54.0	46.0/66.5
		Operating/Max. consumption(kw)	27.6/34.6	28.0/42.5
	Power consumption when heating at low temp.(kw)		26.0	26.0
Output power of outdoor motor(KW)		1.05(0.35*3)	1.4(0.35*4)	
Exterior dimensions (mm)		3010*750*1700	4020*750*1700	
Weight (Kg)		705(235*3)	940(235*4)	
Exterior colour		ivory		
Compressor model		scroll		
Outdoor airflow (m3/min)		501(167*3)	668(167*4)	
Refrigerant (R22) charge (Kg)		33.0(13.0+10.0*2)	43.0(13.0+10.0*3)	
Piping dimension	Gas piping(mm)	F44.5(F28.58*3)	F44.5(F28.58*4)	
	Liquid piping(mm)	F22.22(F12.7*3)	F22.22(F12.7*4)	
	Equipoise/Oil equalization piping(mm)	F19.05/F9.52		
Noise level(dB(A))		62	62	

Equivalent HP		34	36	
Model		AV34NMTAHA	AV36NMTAHA	
Combination mode		AU96NMTAHA AU78NMTAAA*3	AU96NMTAHA AU96NMTAAA AU78NMTAAA*2	
Nominal cooling capacity(KW)		95.8	101.2	
Nominal heating capacity(KW)		106.5	113.0	
Heating capacity at low temp.(KW)		82.8	87.6	
Power source		3N~, 380V, 50Hz		
Electrical characteristics	Cooling	Operating/Max. current(A)	54.3/72.2	57.9/73.8
		Operating/Max. consumption(kw)	32.35/45.9	34.65/46.9
	Heating	Operating/Max. current(A)	51/69.7	54.3/70.0
		Operating/Max. consumption(kw)	30.6/44.5	32.6/44.8
	Power consumption when heating at low temp.(kw)		28.5	30.5
Output power of outdoor motor(KW)		1.4(0.35*4)	1.4(0.35*4)	
Exterior dimensions (mm)		4020*750*1700	4020*750*1700	
Weight (Kg)		940(235*4)	940(235*4)	
Exterior colour		ivory		
Compressor model		scroll		
Outdoor airflow (m3/min)		668(167*4)		
Refrigerant (R22) charge (Kg)		43.0(13.0+10.0*3)		
Piping dimension	Gas piping(mm)	F44.5(F28.58*4)		
	Liquid piping(mm)	F22.22(F12.7*4)		
	Equipoise/Oil equalization piping(mm)	F19.05/F9.52		
Noise level(dB(A))		62	62	



Equivalent HP	38			40				
Model	AV38NMTAHA			AV40NMTAHA				
Combination mode	AU96NMTAHA	AU96NMTAAA*2	AU78NMTAAA	AU96NMTAHA	AU96NMTAAA*3			
Nominal cooling capacity(KW)	106.6			112.0				
Nominal heating capacity(KW)	119.5			126.0				
Heating capacity at low temp.(KW)	92.4			97.2				
Power source	3N~, 380V, 50Hz							
Electrical characteristics	Cooling	Operating/Max. current(A)			61.5/75.4		65.1/77.0	
		Operating/Max. consumption(kw)			36.95/47.9		39.25/48.9	
	Heating	Operating/Max. current(A)			57.6/70.3		60.9/70.6	
		Operating/Max. consumption(kw)			34.6/45.1		36.6/45.4	
	Power consumption when heating at low temp.(kw)			32.5		34.5		
	Output power of outdoor motor(KW)			1.4(0.35*4)		1.4(0.35*4)		
Exterior dimensions (mm)			4020*750*1700		4020*750*1700			
Weight (Kg)			940(235*4)		940(235*4)			
Exterior colour			ivory					
Compressor model			scroll					
Outdoor airflow (m3/min)			668(167*4)					
Refrigerant (R22) charge (Kg)			43.0(13.0+10.0*3)					
Piping dimension	Gas piping(mm)			F44.5(F28.58*4)				
	Liquid piping(mm)			F22.22(F12.7*4)				
	Equipoise/Oil equalization piping(mm)			F19.05/F9.52				
Noise level(dB(A))			63		63			



(2) Indoor unit

A. Low static pressure duct type

Model	AD072ML AHA	AD092ML AHA	AD122ML AHA	AD142ML AHA	AD162ML AHA	AD182ML AHA	AD242ML AHA	
Nominal cooling capacity(KW)	2.2	2.8	3.6	4.0	4.5	5.6	7.1	
Nominal heating capacity(KW)	2.6	3.4	4.0	4.5	5.0	6.3	8.0	
Electrical heating power(KW) /Current(A)	0.8/3.64	0.8/3.64	1.0/4.55	1.0/4.55	1.2/5.45	1.2/5.45	2.0/9.09	
Electrical characteristics	Power source	1PH, 220V~, 50Hz						
	Operating current(A)	0.15	0.15	0.28	0.28	0.3	0.3	0.55
	Power consumption(KW)	0.03	0.03	0.055	0.055	0.06	0.06	0.11
Fan characteristics	Standard airflow(m ³ /h)	520	520	650	700	1000	1000	1500
	Standard static pressure(Pa)	0						
	Max. static pressure(Pa)	30						
Exterior dimensions(mm)	783*450 *225	783*450 *225	937*450 *225	937*450* 225	1230*450 *225	1230*450 *225	1448*450 *225	
Air outlet dimensions(mm)	615*100	615*100	770*100	770*100	1064* 100	1064* 100	1215* 100	
Weight(Kg)	22	22	24	24	30	30	46	
Expansion mode	Electronic expansion valve							
Controller	Wired controller/ wireless controller (optional)							
Piping dimension	Gas piping(mm)	∅12.7	∅12.7	∅12.7	∅12.7	∅12.7	∅15.88	∅15.88
	Liquid piping(mm)	∅6.35	∅6.35	∅6.35	∅6.35	∅6.35	∅9.52	∅9.52
	Drain hose(mm)	∅16.5	∅16.5	∅16.5	∅16.5	∅16.5	∅16.5	∅16.5
Noise level(dB(A)) H/M/L	35/32/30	35/32/30	35/32/30	35/32/30	36/33/31	37/36/34	39/37/35	



B. 4-way cassette type

Model		AB072MCAHA	AB092MCAHA	AB122MCAHA	AB142MCAHA	AB162MCAHA
Nominal cooling capacity(KW)		2.2	2.8	3.6	4.0	4.5
Nominal heating capacity(KW)		2.5	3.2	4.0	4.5	5.0
Electrical characteristics	Power source	1PH, 220V~, 50Hz				
	Operating current(A)	0.47				
	Power consumption(KW)	0.08				
Fan characteristics	Standard airflow(m ³ /h)	700				
	Standard static pressure(Pa)	0				
	Max. static pressure(Pa)	-----				
Exterior dimensions(mm)		570*570*260				
Panel exterior dimensions(mm)		700*700*609				
Weight(Kg)		19+2.8				
Expansion mode		Electronic expansion valve				
Controller		Wired controller/ wireless controller (optional)				
Piping dimension	Gas piping(mm)	Ø 12.7	Ø 12.7	Ø 12.7	Ø 12.7	Ø 12.7
	Liquid piping(mm)	Ø 6.35	Ø 6.35	Ø 6.35	Ø 6.35	Ø 6.35
	Drain hose(mm)	Ø 32	Ø 32	Ø 32	Ø 32	Ø 32
Noise level(dB(A)) H/M/L		32/30/29	32/30/29	32/30/29	33/30/29	33/30/29



Model	AB182MC AHA	AB242M CAHA	AB282MC AHA	AB322MC AHA	AB382MC AHA	AB482MC AHA	
Nominal cooling capacity(KW)	5.6	7.1	8.0	9.0	11.2	14.0	
Nominal heating capacity(KW)	6.3	8.0	9.0	10.0	12.5	16.0	
Electrical heating power(KW) /Current(A)	2.1/9.55	2.1/9.55	2.1/9.55	2.7/12.3	2.7/12.3	2.7/12.3	
Electrical characteristics	Power source	1PH, 220V~, 50Hz					
	Operating current(A)	0.45	0.51	0.51	0.76	0.76	0.76
	Power consumption(KW)	0.09	0.1	0.1	0.15	0.15	0.15
Fan characteristics	Standard airflow(m ³ /h)	1020			1920		
	Standard static pressure(Pa)	0					
	Max. static pressure(Pa)	-----					
Exterior dimensions(mm)	840*840*240			840*840*295			
Panel exterior dimensions(mm)	950*950*80						
Weight(Kg)	36(30+6)			44(38+6)			
Controller	Wired controller/ wireless controller (optional)						
Piping dimension	Gas piping(mm)	∅ 15.88	∅ 15.88	∅ 15.88	∅ 15.88	∅ 19.05	∅ 19.05
	Liquid piping(mm)	∅ 9.52					
	Drain hose(mm)	∅ 32					
	Connecting method	Flared joint					
Noise level(dB(A)) H/M/L	34/32/30	35/34/31	37/35/31			42/39/35	



C. Wall mounted type

Model		AS072MCAHA	AS092MCAHA	AS122MCAHA	AS142MCAHA	AS162MCAHA	AS182MCAHA
Nominal cooling capacity(KW)		2.2	2.8	3.6	4.0	4.5	5.6
Nominal heating capacity(KW)		2.5	3.2	4.0	4.5	5.0	6.3
Electrical characteristics	Power source	1PH, 220V~, 50Hz					
	Operating current(A)	0.08			0.1	0.25	
	Power consumption(KW)	0.015			0.02	0.05	
Fan characteristics	Standard airflow(m ³ /h)	600		630		760	
	Standard static pressure(Pa)	0					
	Max. static pressure(Pa)	-----					
Exterior dimensions(mm)		795*197*265				928*197*265	
Air outlet dimensions(mm)		600*85				850*85	
Weight(Kg)		10				13	
Controller		Wired controller/ wireless controller (optional)					
Piping dimension	Gas piping(mm)	Ø 12.7				Ø 15.88	
	Liquid piping(mm)	Ø 6.35				Ø 9.52	
	Drain hose(mm)	Ø 16.5					
	Connecting method	Flared joint + brazing					
Noise level(dB(A)) H/M/L		34/30/29		35/32/29		38/36/32	



D. Middle static pressure duct type

Model	AD322MMAHA	AD382MMAHA	AD482MMAHA
Nominal cooling capacity(KW)	9.0	11.2	14.0
Nominal heating capacity(KW)	10.0	12.5	16.0
Electrical heating power(KW) /Current(A)	2.4/10.91	2.4/10.91	2.4/10.91
Electrical characteristics	Power source	1PH, 220V, 50Hz	
	Operating current(A)	0.51	
	Power consumption(KW)	0.1	
Fan characteristics	Standard airflow(m ³ /h)	1900	2100
	Standard static pressure(Pa)	50	
	Max. static pressure(Pa)	96	
Exterior dimensions(mm)	1410*645*350		
Air outlet dimensions(mm)	Ø200*4		
Weight(Kg)	57		
Controller	Wired controller/ wireless controller (optional)		
Accessories	Use for installation		
Piping dimension	Gas piping(mm)	Ø 15.88	Ø 19.05
	Liquid piping(mm)	Ø 9.52	
	Drain hose(mm)	Ø 32	
Noise level(dB(A)) H/M/L	43/37/35		44/40/36



7. Optional accessories list

Name	Model	Units	Code number	Remark
Gather pipe assembly	HZG-20	AV16,18,20NMTAHA	AZOG8000000	
	HZG-30	AV24,26,28,30NMTAHA	AZOG9000000	
	HZG-40	AV32,34,36,38,40NMTAHA	AZOGA0000000	
Branch pipe assembly	FQG-B120	-----	10105904000	
	FQG-B180	-----	10100802800	
	FQG-B370	-----	10100802700	
	FQG-B700	-----	AZ0GB000000	
	FQG-B1100	-----	AZ0GC000000	
	FQG-B1460	-----	AZ0GD000000	
Standard wired controller	YR-E12	All indoor units	AZ0H8000000	
Remote controller	YR-H39	AD322,482MM/MLAHA	AZ0HA000000	With the remote receiver
Remote controller	YR-H39	AS072~182MCAHA AB072~162MCAHA	10105904900	The remote receiver is in the panel or the front panel
Remote controller	YR-H39	KMR(d)- 56~140Q/520B	AZ0LJ000000	with the remote receiver and the panel
Group controller	YR-E12	All indoor units	AZ0JD000000	Max. 16 (Group) indoor units
Central controller	ICR01	All indoor units	AZ0K5000000	Max. 64 (Group) indoor units
Connection board	IGU04	All indoor units	AZ0K6000000	Used with the ICR01 assembly(1: 64), can be installed in the electrical box of master unit

2.2 Performance curves

1. Running range

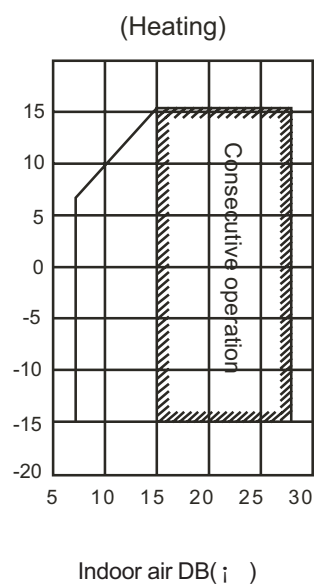
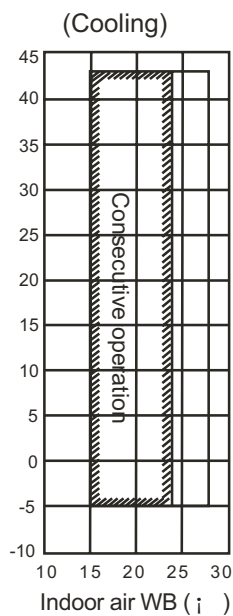



2. Calculation method

(1) Calculation method of refrigerating capacity---Refrigerating capacity to be known

=Refrigerating capacity x (A x B x C x D x E) W

A. Capacity compensation value of indoor air wet-bulb temperature condition

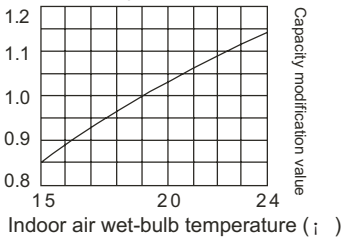

B. Capacity compensation value of outdoor air dry-bulb temperature condition

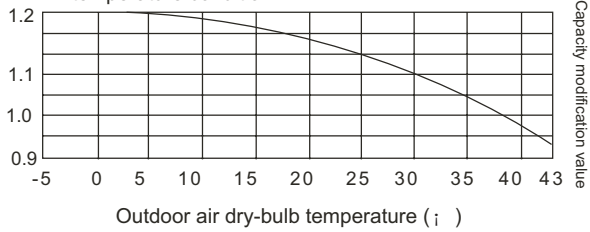

C. Fall of refrigerant pipe of indoor and outdoor unit, capacity compensation value of pipe length

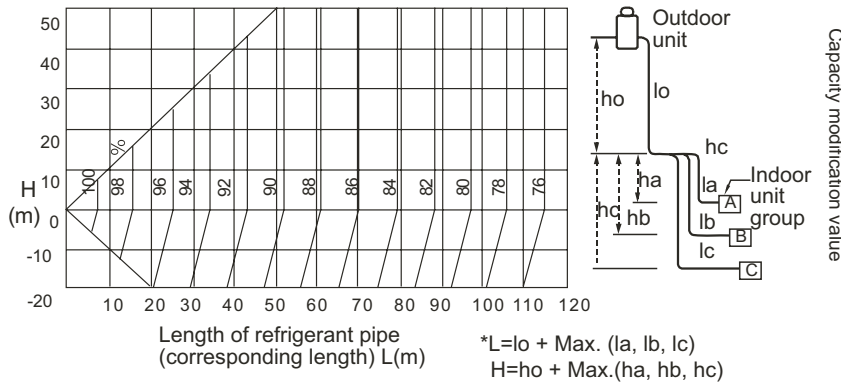

D. Capacity modification value under airflow variation rate of indoor unit group (only for duct unit)

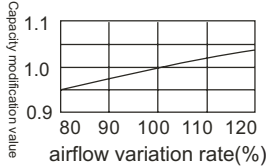

E. Capacity compensation suitable for total capability of indoor unit group (cooling)

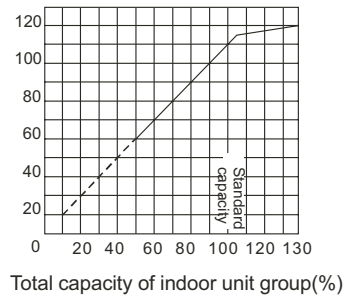

(2) Calculation method of heating capacity---Heating capacity to be known

= Heating capacityx (A x B x C x D x E x F) W

A. Capacity modification under indoor air dry-bulb temperature condition

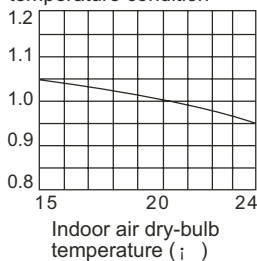

B. Capacity modification under outdoor air wet-bulb temperature condition

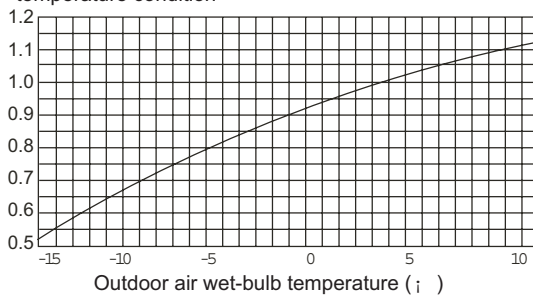

C. Capacity modification value under airflow variation rate of indoor unit group

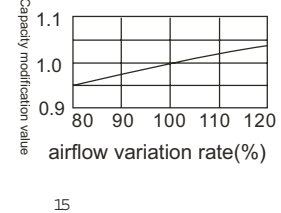



D. Fall of refrigerant pipe of indoor and outdoor unit, capacity compensation value of pipe length

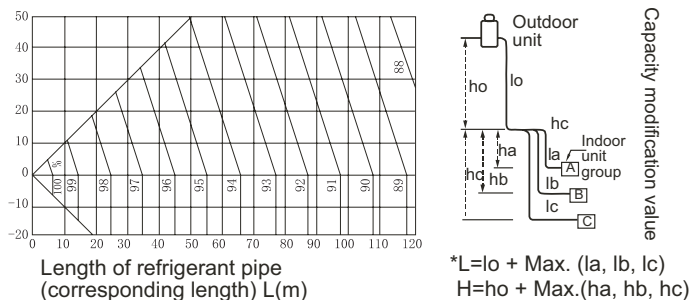

E. Capacity compensation suitable for total capability of indoor unit group (heating)

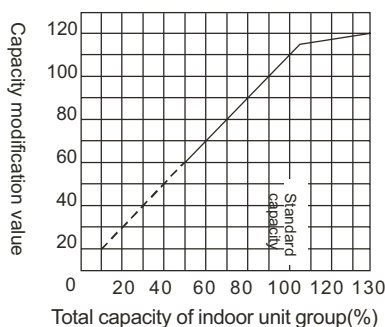

F. Capacity compensation value for defrost capability of outdoor heat exchanger

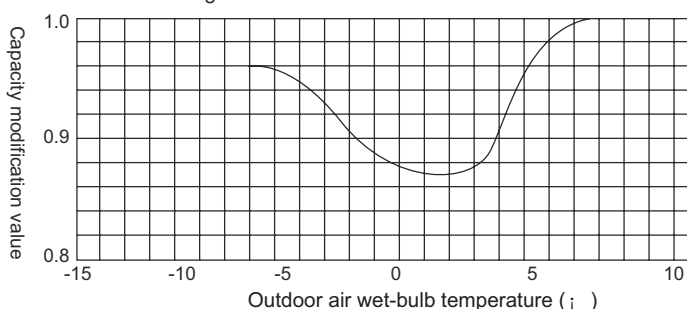

(3) Calculation method of refrigerating capacity---Only one indoor unit running

$$\text{Outdoor modified capacity with a single indoor running} = \text{outdoor modified capacity} * \frac{\text{standby indoor nominal capacity}}{\text{Indoor total nominal capacity}}$$

(Outdoor modified capacity: heating or cooling capacity after modify item 1 and 2)

2.3 Noise level

1. Outdoor running noise:

(1) Testing illustrate:

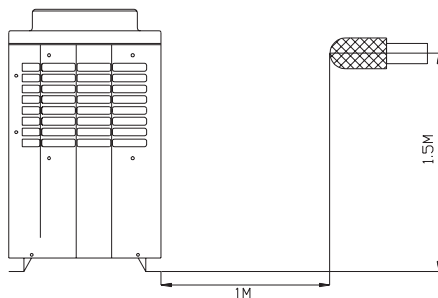

(2) Testing condition:

- a. Unit running in the nominal condition
- b. Test in the semi-anechoic chamber
- c. Noise level varies from the actual factors such as room structure, etc.

(3) Noise level dB(A):

Air speed	Outdoor unit group(380V, 50HZ)												
	8HP	10HP	16HP	18HP	20HP	24HP	26HP	28HP	30HP	32HP	34HP	36HP	38HP
H	57	58	60		61			62			63		



(4) Octave band level

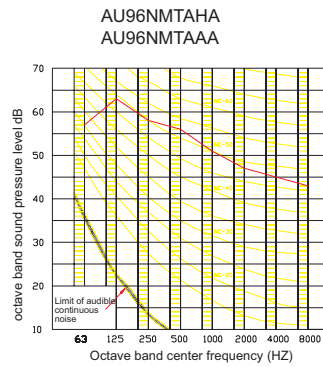
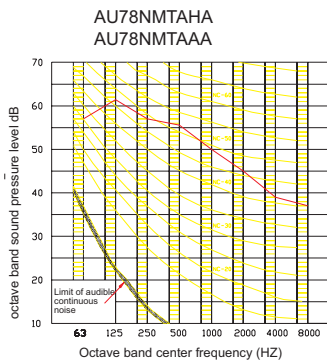

2. Ceiling concealed duct type running noise:

(1) Testing illustrate:

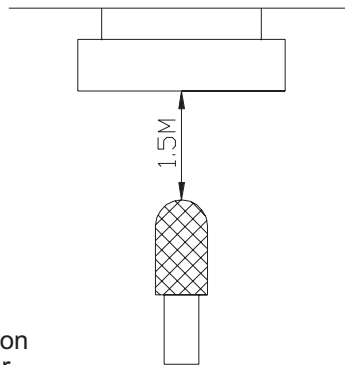

(2) Testing condition:

- a. Unit running in the nominal condition
- b. Test in the semi-anechoic chamber
- c. Noise level varies from the actual factors such as room structure, etc.

(3) Noise level dB(A):

Air speed	Ceiling concealed duct type (220V, 50HZ)						
	22(0.8)	28(1.0)	36(1.25)	40(1.5)	45(1.7)	56(2.0)	71(2.5)
H			35		36	37	39
M			32		33	36	37
L			30		31	34	35

(4) Octave band level

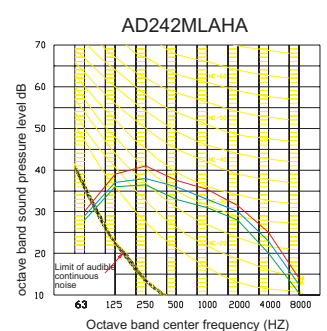
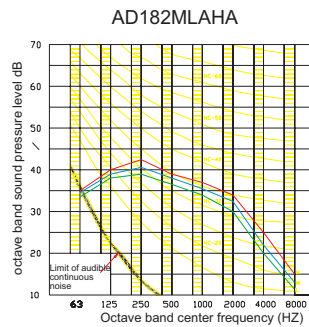
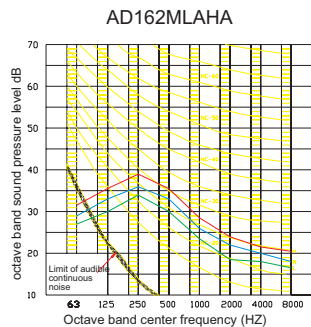
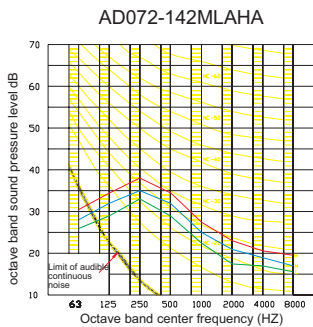



3. 4-way cassette type running noise:

(1) Testing illustrate:

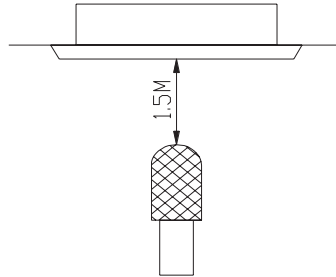

(2) Testing condition:

- a. Unit running in the nominal condition
- b. Test in the semi-anechoic chamber
- c. Noise level varies from the actual factors such as room structure, etc.

(3) Noise level dB(A):

Air speed	4-way cassette type (220V, 50HZ)										
	22(0.8)	28(1.0)	36(1.25)	40(1.5)	45(1.7)	56(2.0)	71(2.5)	80(3.0)	90(3.2)	112(4.0)	140(5.0)
H		32			33	34	35			37	42
M		30			30	32	34			35	39
L		29			29	30	31			31	35

(4) Octave band level

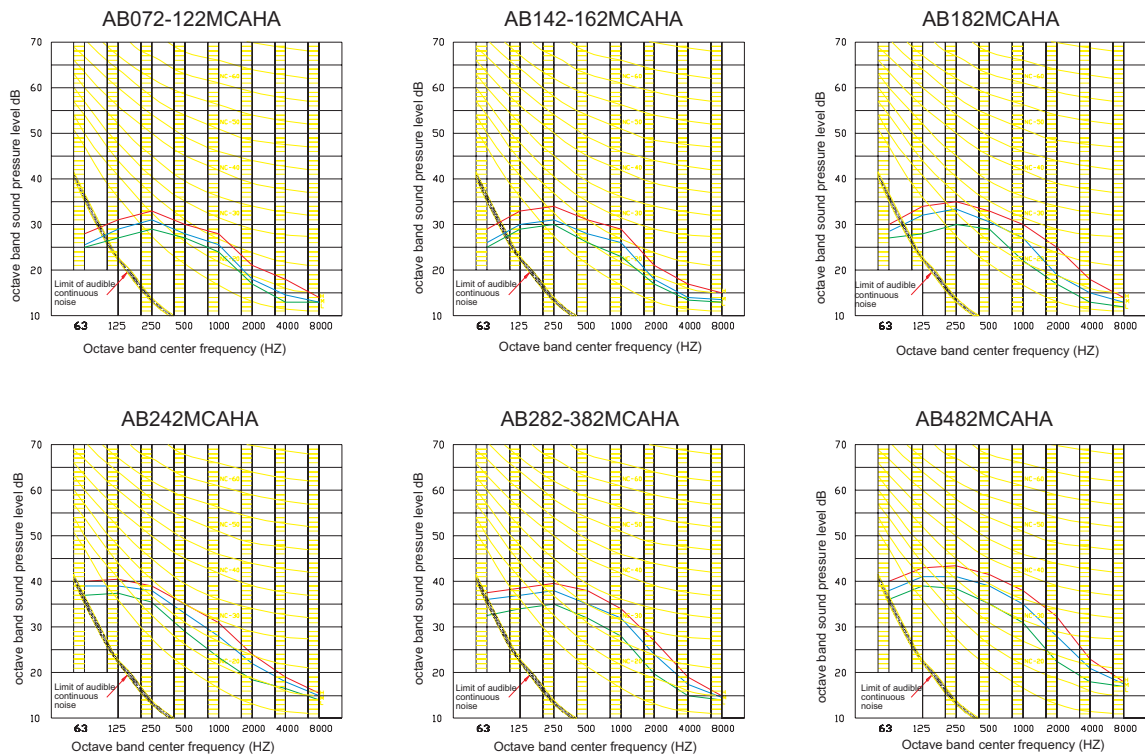



4. Wall mounted type running noise:

(1) Testing illustrate:

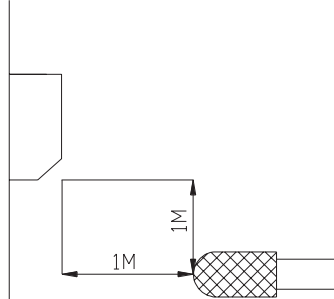

(2) Testing condition:

- a. Unit running in the nominal condition
- b. Test in the semi-anechoic chamber
- c. Noise level varies from the actual factors such as room structure, etc.

(3) Noise level dB(A):

Air speed	Wall mounted type (220V,50HZ)					
	22(0.8)	28(1.0)	36(1.25)	40(1.5)	45(1.7)	56(2.0)
H	34		35		38	
M	30		32		36	
L	29		29		32	

(4) Octave band level

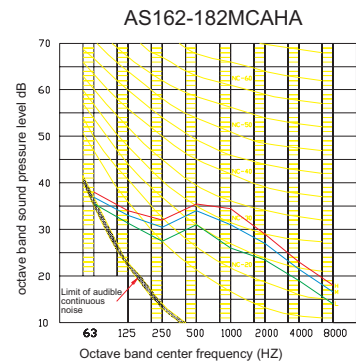
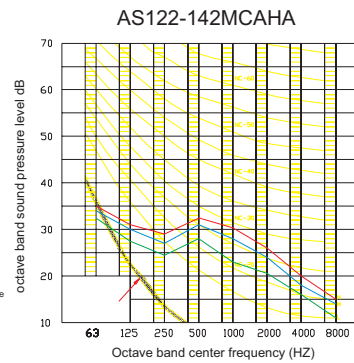
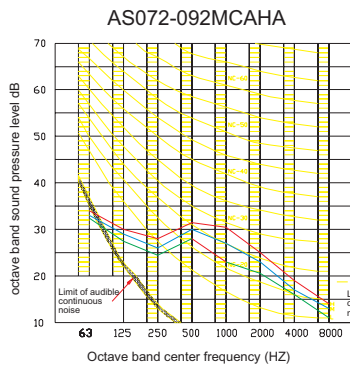



5. Middle static pressure duct type running noise:

(1) Testing illustrate:

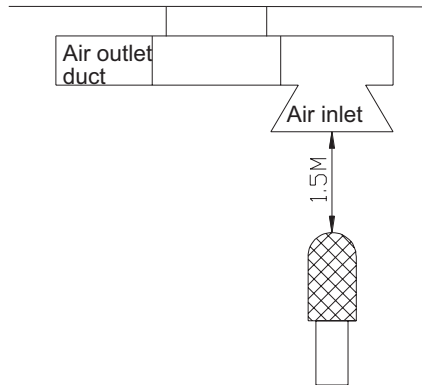

(2) Testing condition:

- a. Unit running in the nominal condition
- b. Test in the semi-anechoic chamber
- c. Noise level varies from the actual factors such as room structure, etc.

(3) Noise level dB(A):

Air speed	Middle static pressure duct type (220V, 50HZ)		
	90(3.2)	112(4.0)	140(5.0)
H	43	43	44
M	37	37	40
L	35	35	36

(4) Octave band level

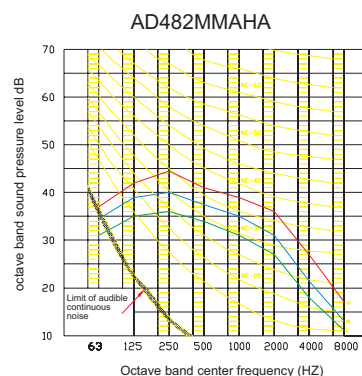
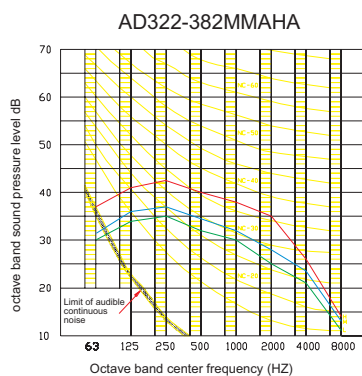



Installation instruction

- 3.1 Outdoor installation
- 3.2 Indoor installation
- 3.3 Circuit diagram
- 3.4 Electric installation



3.1 Outdoor installation

SAFETY PRECAUTIONS

Please read these "Safety Precautions" first then accurately execute the installation work.

Though the precautionary points indicated herein are divided under two headings, "WARNING" and "CAUTION", those points which are related to the strong possibility of an installation done in error resulting in death or serious injury are listed in the "WARNING" section. However, there is also a possibility of serious consequences in relationship to the points listed in the "CAUTION" section as well. In either case, important safety related information is indicated, so by all means, properly observe all that is mentioned.

After completing the installation, along with confirming that no abnormalities were seen from the operation tests, please explain operating methods as well as maintenance methods to the user (customer) of this equipment, based on the owner's manual.

Moreover, ask the customer to keep this sheet together with the owner's manual.

WARNING

This system should be applied to places of office, restaurant, residence and the like. Application to inferior environment such as engineering shop could cause equipment malfunction.

Please entrust installation to either the company which sold you the equipment or to a professional contractor. Defects from improper installations can be the cause of water leakage, electric shocks and fires.

Execute the installation accurately, based on following the installation manual. Again, improper installations can result in water leakage, electric shocks and fires.

When a large air-conditioning system is installed to a small room, it is necessary to have a prior planned countermeasure for the rare case of a refrigerant leakage, to prevent the exceeding of threshold concentration. In regards to preparing this countermeasure, consult with the company from which you purchased the equipment, and make the installation accordingly. In the rare event that a refrigerant leakage and exceeding of threshold concentration does occur, there is the danger of a resultant oxygen deficiency accident.

For installation, confirm that the installation site can sufficiently support heavy weight. When strength is insufficient, injury can result from a falling of the unit.

Execute the prescribed installation construction to prepare for earthquakes and the strong winds of typhoons and hurricanes, etc. Improper installations can result in accidents due to a violent falling over of the unit.

For electrical work, please see that a licensed electrician executes the work while following the safety standards related to electrical equipment, and local regulations as well as the installation instructions, and that only exclusive use circuits are used. Insufficient power source circuit capacity and defective installment execution can be the cause of electric shocks and fires.

Accurately connect wiring using the proper cable, and insure that the external force of the cable is not conducted to the terminal connection part, through properly securing it. Improper connection or securing can result in heat generation or fire.

Take care that wiring does not rise upward, and accurately install the lid/service panel. Its improper installation can also result in heat generation or fire.

When setting up or moving the location of the air conditioner, do not mix air etc. or anything other than the designated refrigerant (please see nameplate) within the refrigeration cycle.

Rupture and injury caused by abnormal high pressure can result from such mixing.

Always use accessory parts and authorized parts for installation construction. Using parts not authorized by this company can result in water leakage, electric shock, fire and refrigerant leakage.



CAUTION

Execute proper grounding. Do not connect the ground wire to a gas pipe, water pipe, lightning rod or a telephone ground wire.

Improper placement of ground wires can result in electric shock.

The installation of an earth leakage breaker is necessary depending on the established location of the unit. Not installing an earth leakage breaker may result in electric shock.

Do not install the unit where there is a concern about leakage of combustible gas. The rare event of leaked gas collecting around the unit could result in an outbreak of fire.

For the drain pipe, follow the installation manual to insure that it allows proper drainage and thermally insulate it to prevent condensation. Inadequate plumbing can result in water leakage and water damage to interior items.

1. Refrigerant pipe

(1) Piping selection chart(unit of capacity: 100W)

Total capacity of indoor units	Capacity	Gas pipe	Liquid pipe	Branch pipe
	~101	Ø 15.88	Ø 9.52	FQG-B120
	101~180	Ø 19.05	Ø 9.52	FQG-B180
	180~371	Ø 28.58	Ø 12.7	FQG-B370
	371~540	Ø 31.8	Ø 15.88	FQG-B700
	540~700	Ø 38.1	Ø 19.05	
	700~1100	Ø 44.5	Ø 22.22	FQG-B1100
	1100~	Ø 50.8	Ø 25.4	FQG-B1460

Remark: A. Adjust the sub-pipe diameter when the pipes between the sub-pipe and unit need to be adjusted;

B. Select the pipe and branch pipe by the total capacity after indoor unit pipe and sub-pipe.



(2) Gather pipe for combination of outdoor unit

HZG-20 HZG-30 HZG-40

A. Structures of outdoor unit gather pipe (unit:mm, ID: inner diameter; OD: outer diameter)

Note: Cut off the pipe from its middle when using

Model	Side	Mark	Manifold pipe	Insulation material	Side	Mark	
HZG-20	Gas side	Ⓐ			Gas side	①	
	Liquid side	Ⓑ				②	
HZG-30	Gas side	Ⓒ			Gas side	③	
		Ⓓ				④	
	Liquid side	Ⓔ				⑤	
HZG-40	Gas side	Ⓕ			Gas side	⑦	
		Ⓖ				⑧	
		Ⓗ				⑨	
	Liquid side	Ⓘ				⑩	
		Ⓙ				⑪	
						⑫	



B. Outdoor unit type

The first branch should be at the inverter outdoor unit.

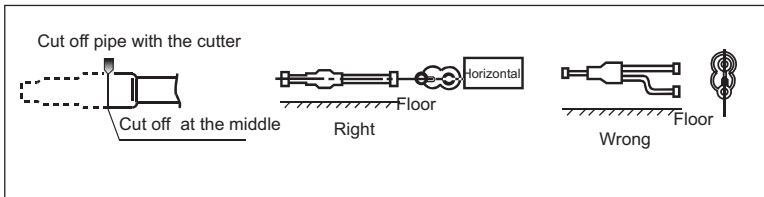
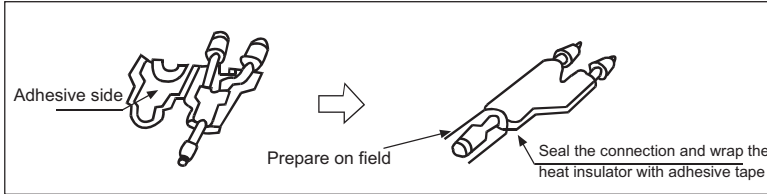

Note:

1. When connecting the gather pipe and the outdoor, please pay attention to the outdoor pipe dimension.
2. When adjusting the diameter among gather pipes and among the units, please must execute at the branch pipe side.
3. Please install the gather pipe(gas/liquid side) in horizontal or vertical direction.
4. When welding with hard solder, please must blow nitrogen. If not, a number of oxide will be produced and cause heavy damage. Besides, to prevent water and dust into the pipe, please make the brim as outer roll.

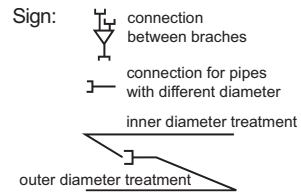

20HP<AU96NMTAHA+AU96NMTAAA>

Gather pipe HZG-20

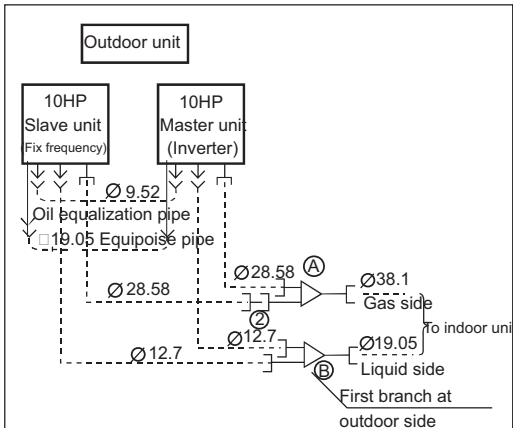

30HP<AU96NMTAHA+AU96NMTAAA*2>

Gather pipe HZG-30

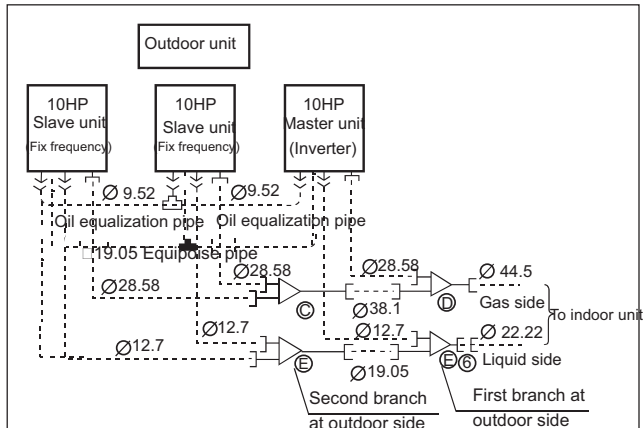

40HP<AU96NMTAHA+AU96NMTAAA*3>

Gather pipe HZG-40

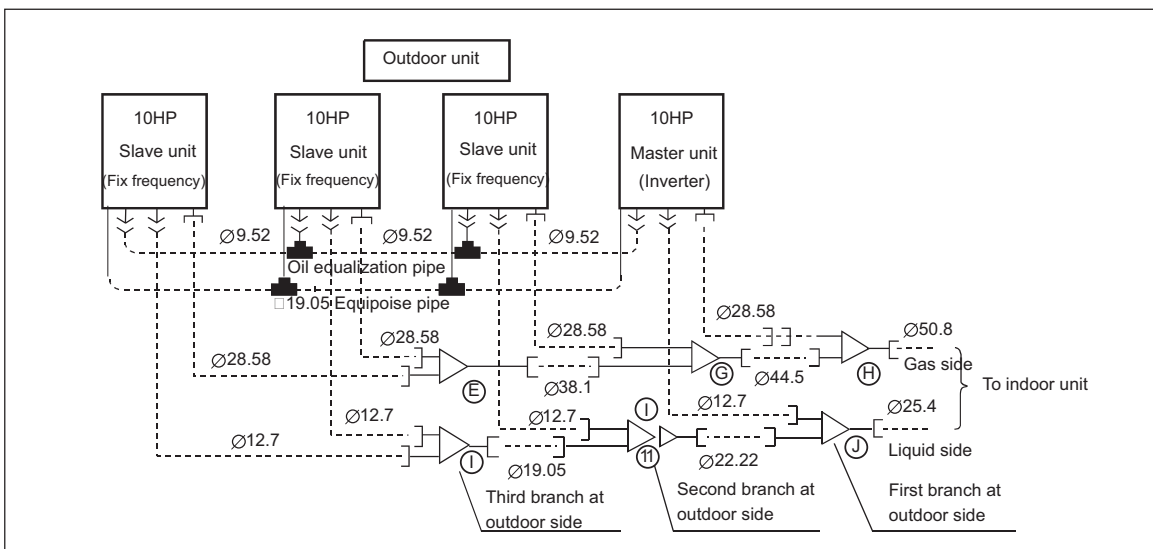



(3) Branch pipe

Branch pipe FQG-B120, FQG-B180, FQG-B370 (unit: mm)

Model	Gas/Liquid pipe	Branch pipe	Changing pipe
FQG-B120	Gas pipe		-----
	Liquid pipe		-----
FQG-B180	Gas pipe		-----
	Liquid pipe		-----
FQG-B370	Gas pipe		
	Liquid pipe		-----



Branch pipe FQG-B700 (unit: mm, ID: inner diameter; OD: outer diameter)

	Gas side	Liquid side
Branch pipe		
Connection of manifold pipe	ID34.92 OD38.1	ID9.52 OD12.7
Connection of manifold pipe	ID12.7 OD15.88	ID6.35 OD12.7
Connection of manifold pipe	ID44.5 OD38.1	ID22.22 OD19.05
Insulation material		

Branch pipe FQG-B1100

	No.	Gas side	No.	Liquid side
Branch pipe				
Changing pipe	1	ID28.58 OD25.8 (Num.: 2)	5	ID9.52 OD12.7
Changing pipe	2	ID15.88 OD19.05	6	ID6.35 OD12.7
Changing pipe	3	ID12.7 OD19.05	7	ID22.22 OD19.05
Changing pipe	4	ID44.5 OD38.1	Note: there is code sign on the changing pipe	
Insulation material				



Branch pipe FQG-B1460 (unit: mm)

	No.	Gas side	No.	Liquid side
Branch pipe				
Changing pipe	1		5	
Changing pipe	2		6	
Changing pipe	3		7	
Changing pipe	4		8	
Insulation material				Note: there is code sign on the changing pipe

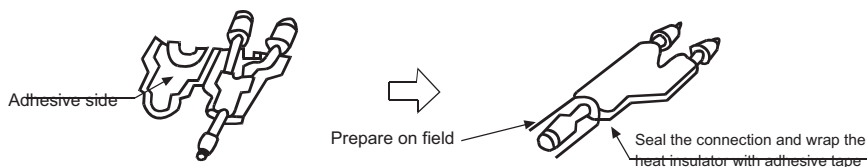

Note:

1. The diameter of pipe between the first branch pipe and outdoor unit should be identical with the main pipe of outdoor unit.
2. The diameter of pipe between branch pipe and indoor unit should be identical with the main pipe of indoor unit.
3. The diameter adjustment of pipe between branch pipe and machine should be proceeded at the branch pipe side.
4. Branch pipe(gas/liquid side) must be installed in horizontal or vertical direction
5. When welding the pipe, please must blow nitrogen. If not, a number of oxide will be produced and cause heavy damage.

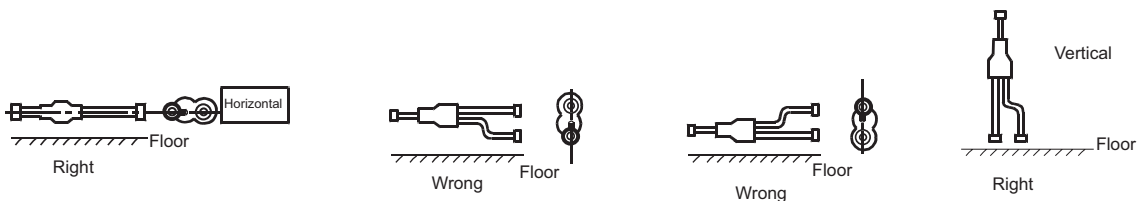
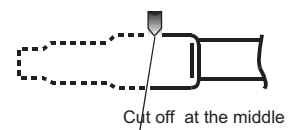



AV26NMTAHA
26HP

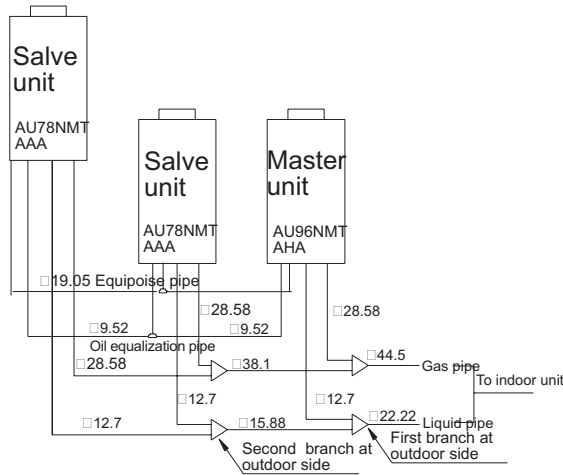

AV28NMTAHA
28HP

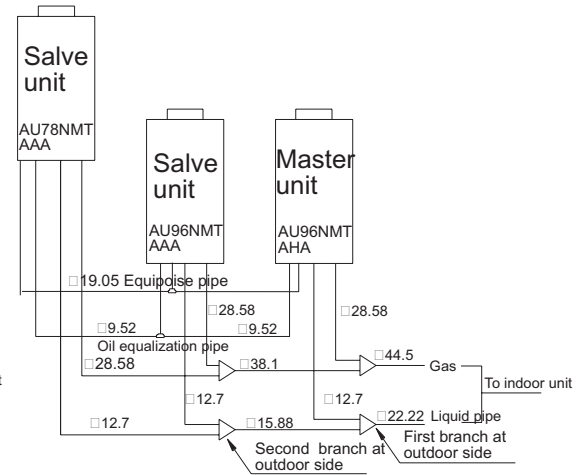

AV30NMTAHA
30HP

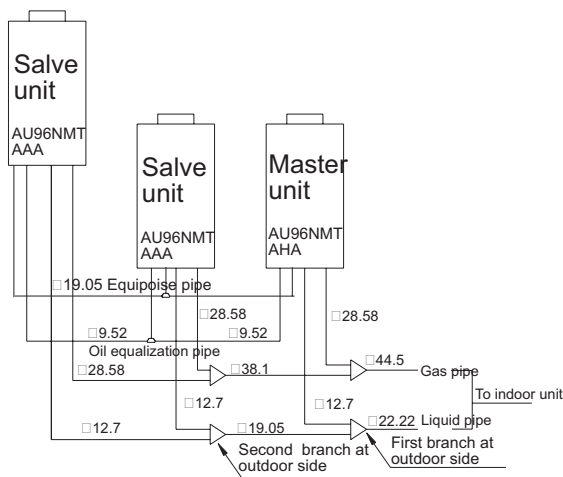

AV32NMTAHA
32HP

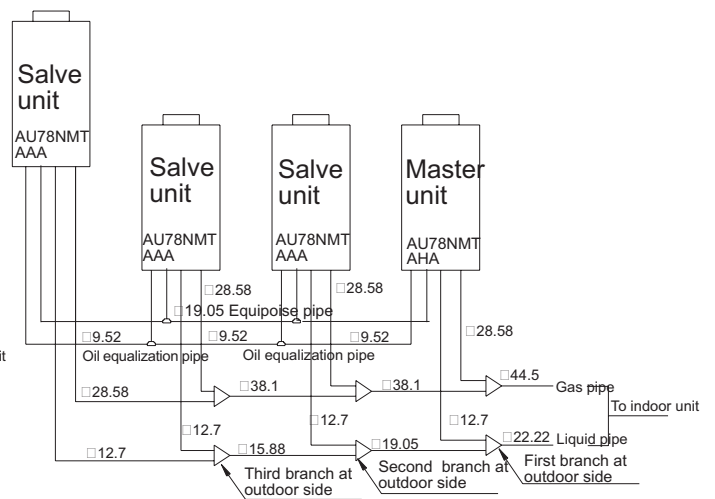



AV34NMTAHA 34HP

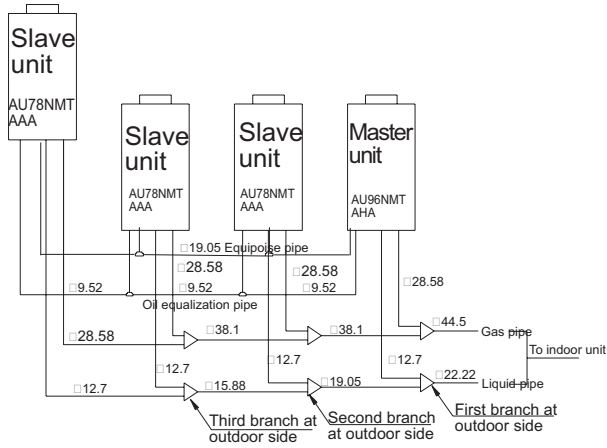

AV36NMTAHA 36HP

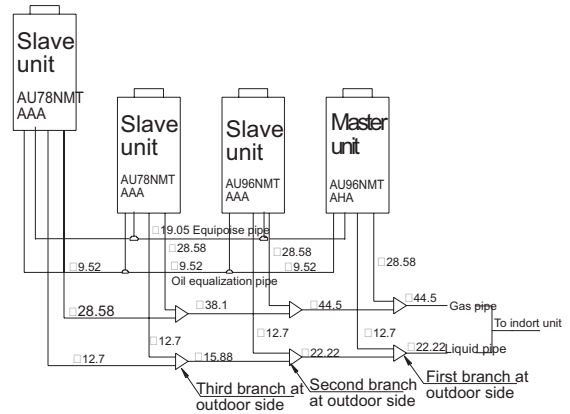

AV38NMTAHA 38HP

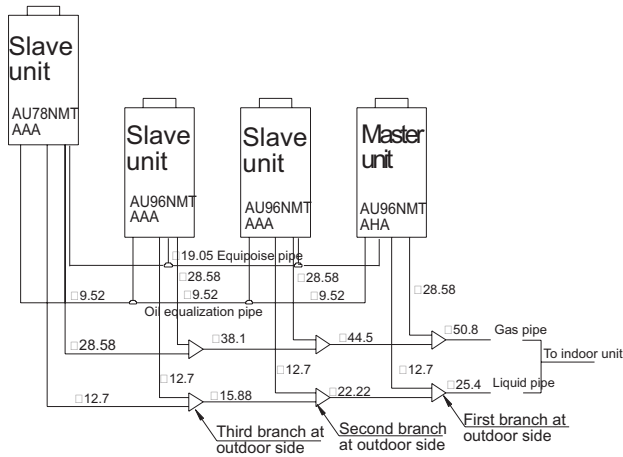

AV40NMTAHA 40HP

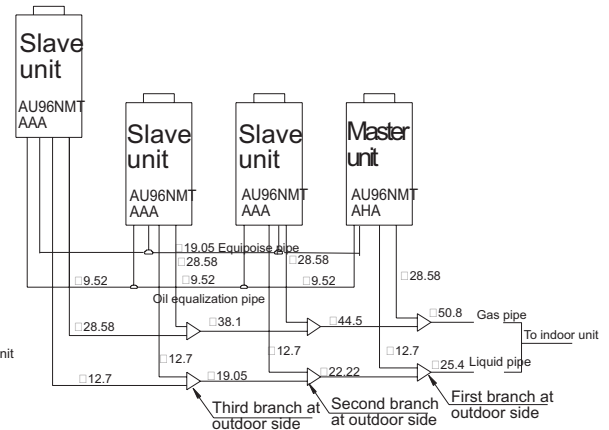



(5) Connection of oil equalization pipe and equipoise pipe

Connect the □9.52 oil equalization pipe and □19.05 equipoise pipe by T shape 3-way pipe, which is supplied when out of factory.

(6) Example for connection of refrigerant pipe (unit: mm)

Branch pipe		Pipe dimension	
		∅ Gas pipe	∅ Liquid pipe
A	FQG- B700	∅ 38.1	∅ 19.05
B	FQG- B370	∅ 28.58	∅ 12.7
C	FQG- B370	∅ 25.4	∅ 12.7
D	FQG- B180	∅ 19.05	∅ 9.52
E	FQG- B120	∅ 15.88	∅ 9.52
F	FQG- B180	∅ 19.05	∅ 9.52

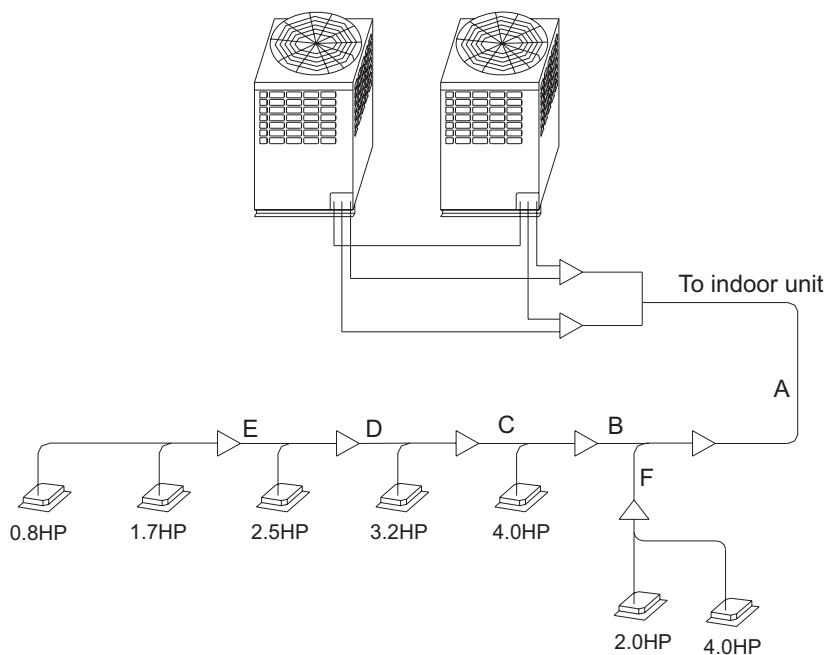

Note:

- A. The changing pipe in the branch pipe set can be used properly due to the piping dimension.
- B. When the dimension of indoor side pipe connector and branch pipe needs to be adjusted, please adjust the branch pipe connector.
- C. Please set the branch pipe at horizontal or vertical direction.



(7) Unit pipe spec and connection method (unit: mm)

A. Outdoor unit

Model	Gas pipe side		Liquid pipe side		Oil pipe side	
	Diameter	Connecting method	Diameter	Connecting method	Diameter	Connecting method
AU96NMTAHA AU96NMTAAA	Ø28.58	Brazing	Ø12.7	Flared joint	Ø9.52	Flared joint
AU78NMTAHA AU78NMTAAA	Ø28.58	Brazing	Ø12.7	Flared joint	Ø9.52	Flared joint

B. Indoor unit

Model Capacity(HP)	Gas pipe side		Liquid pipe side	
	Diameter	Connecting method	Diameter	Connecting method
0.8	Ø12.7	Flared joint (welded with hard solder for Ceiling concealed type)	Ø6.35	Flared joint (welded with hard solder for Ceiling concealed type)
1.0	Ø12.7		Ø6.35	
1.25	Ø12.7		Ø6.35	
1.5	Ø12.7		Ø6.35	
1.7	Ø12.7		Ø6.35	
2.0	Ø15.88		Ø9.52	
2.5	Ø15.88		Ø9.52	
3.0	Ø15.88		Ø9.52	
3.2	Ø15.88		Ø9.52	
4.0	Ø19.05		Ø9.52	
5.0	Ø19.05		Ø9.52	

C. Pipe spec and the torque

diameter	Thickness(mm)	Torque(N.m)
Ø6.35	0.8	14~18
Ø9.52	0.8	34~42
Ø12.7	1.0	
Ø15.88	1.0	68~82
Ø19.05	1.0	100~120
Ø25.4	1.2	---
Not less than Ø28.58	More than 1.4	---



2. Appearance and installation dimension of outdoor unit (unit: mm)

(1) Appearance(single unit)

Note:

A There should be no obstacles in 2000mm above the top of outdoor unit;

B Obstacles around outdoor should be less than 800mm to the bottom of unit.

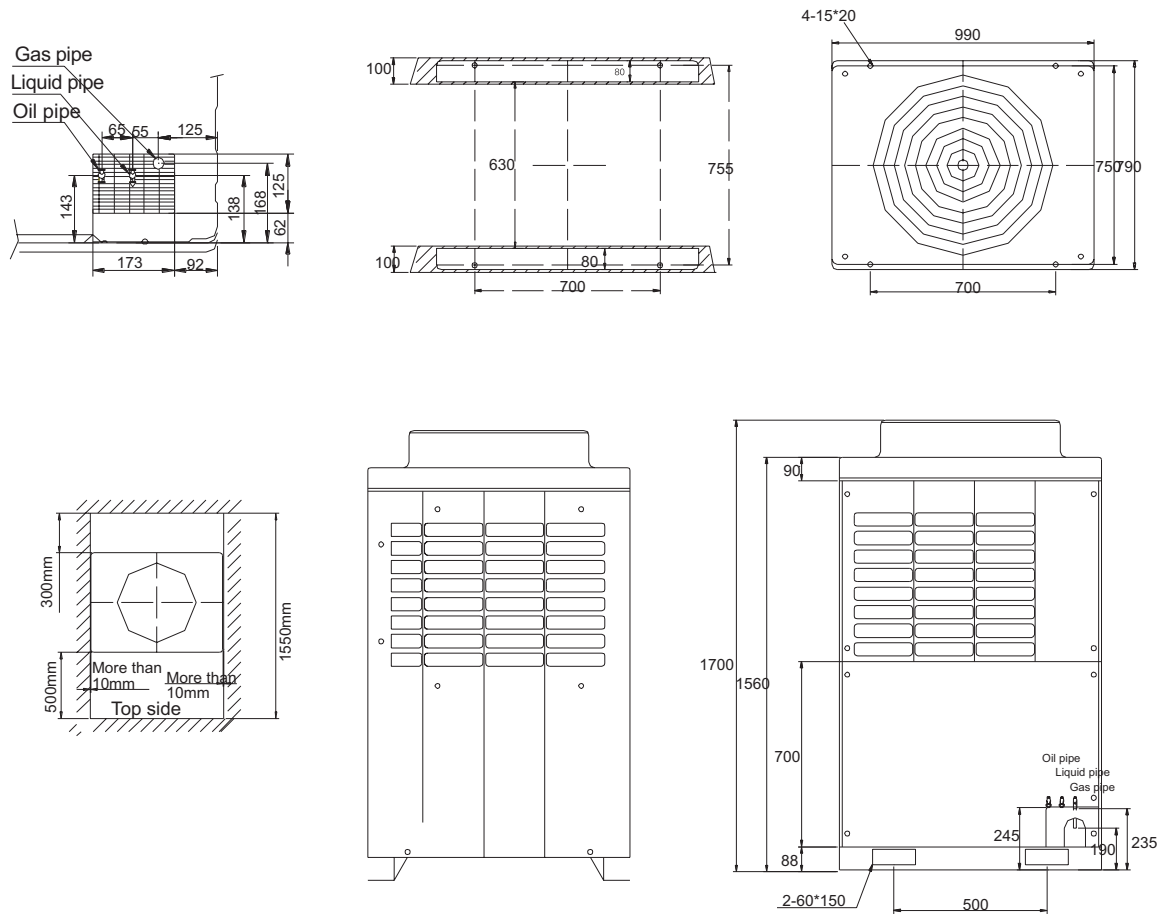



(2) Combined outdoor unit(2 units)

Note:

- A. There should be no obstacles in 2000mm above the top of outdoor unit;
- B. Obstacles around outdoor should be less than 800mm to the bottom of unit.
- C. Master unit should be the nearest one to the first branch pipe;
- D. The distance between two outdoor units in the same line and the distance from unit to the wall can be increased for easy maintenance if there is enough space.

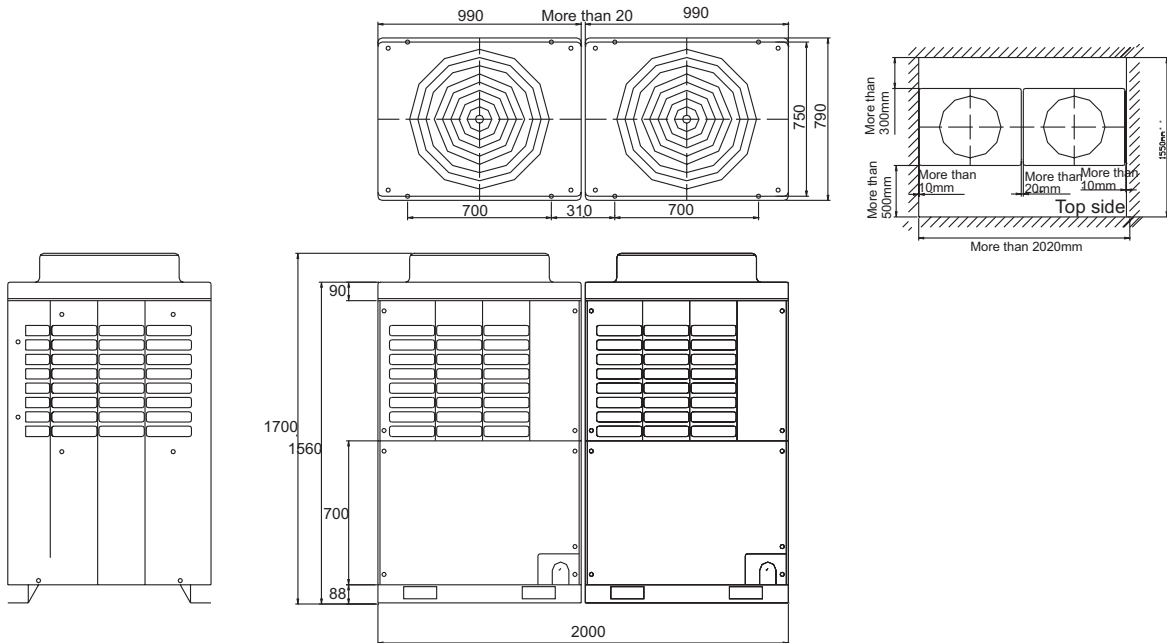

(3) Combined outdoor unit(3 units)

Note:

- A. There should be no obstacles in 2000mm above the top of outdoor unit;
- B. Obstacles around outdoor should be less than 800mm to the bottom of unit.
- C. Master unit should be the nearest one to the first branch pipe;
- D. The distance between two outdoor units in the same line and the distance from unit to the wall can be increased for easy maintenance if there is enough space.

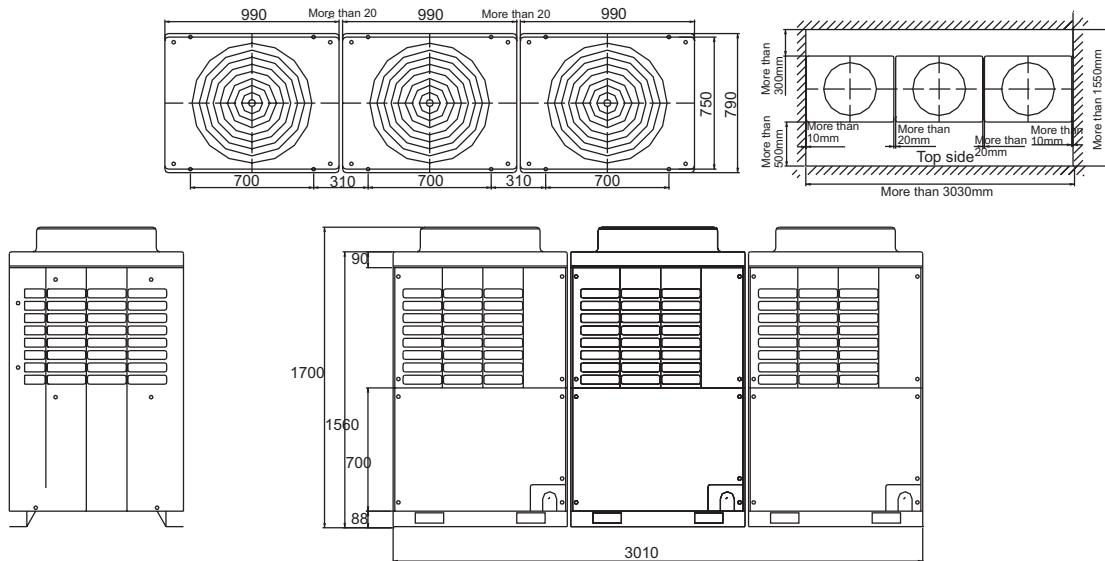



(4) Combined outdoor unit(4 units)

Note:

- A. There should be no obstacles in 2000mm above the top of outdoor unit;
- B. Obstacles around outdoor should be less than 800mm to the bottom of unit.
- C. Master unit should be the nearest one to the first branch pipe;
- D. The distance between two outdoor units in the same line and the distance from unit to the wall can be increased for easy maintenance if there is enough space.

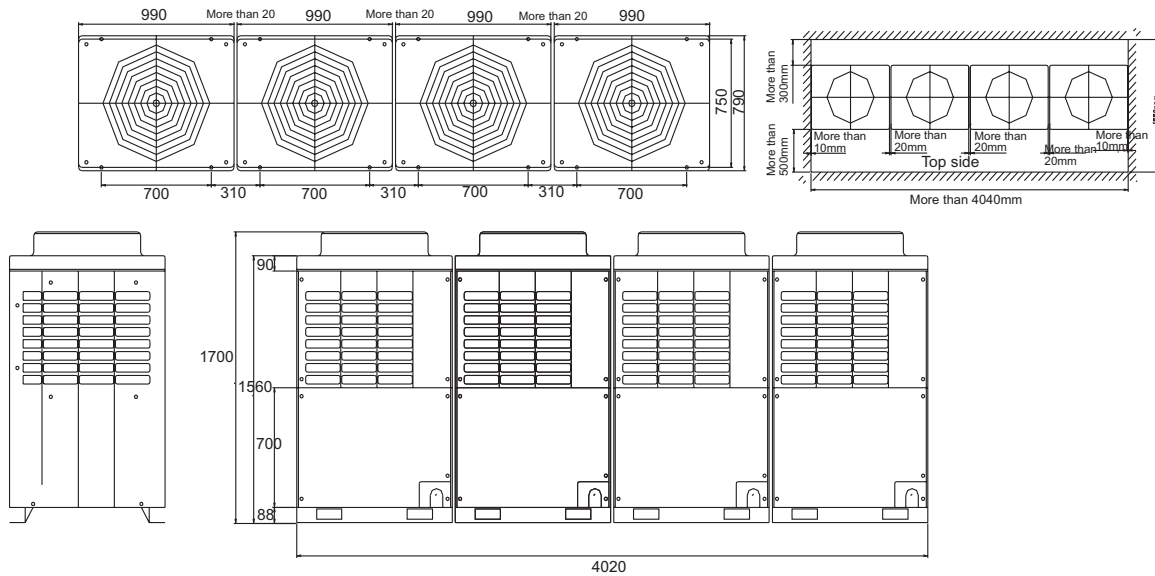

3. Dimensions for outdoor unit in groups

(1) When outer wall is lower than the outdoor condenser

A. Sites for one-row layout

The distance between two outdoor units in the same line and the distance from unit to the wall can be increased for easy maintenance if there is enough space.

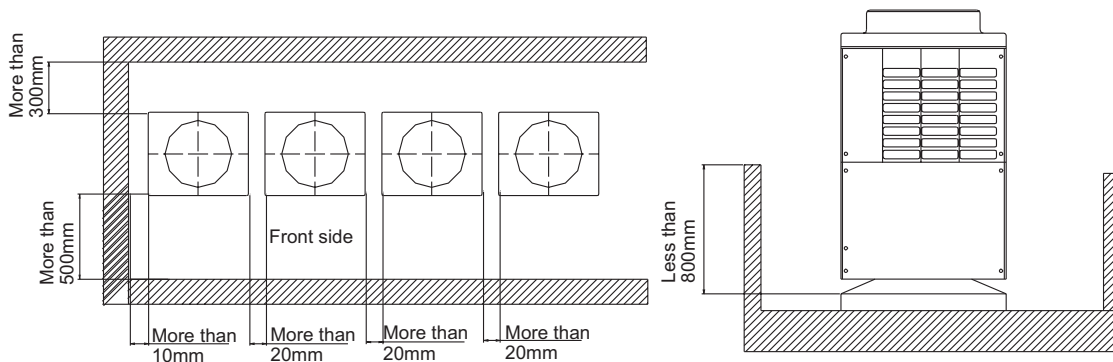



B. Sites for two-row layout

The distance between two outdoor units in the same line and the distance from unit to the wall can be increased for easy maintenance if there is enough space.

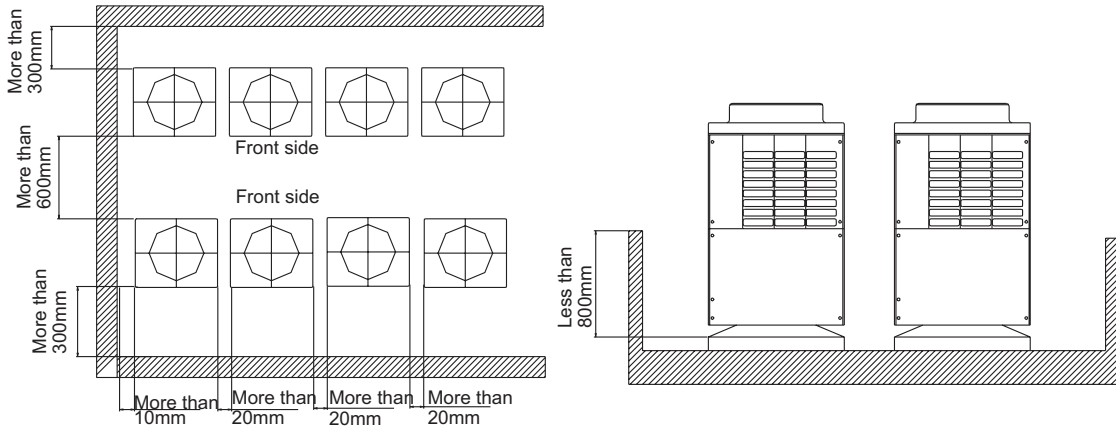

C. Sites for three-row layout

The distance between two outdoor units in the same line and the distance from unit to the wall can be increased for easy maintenance if there is enough space.

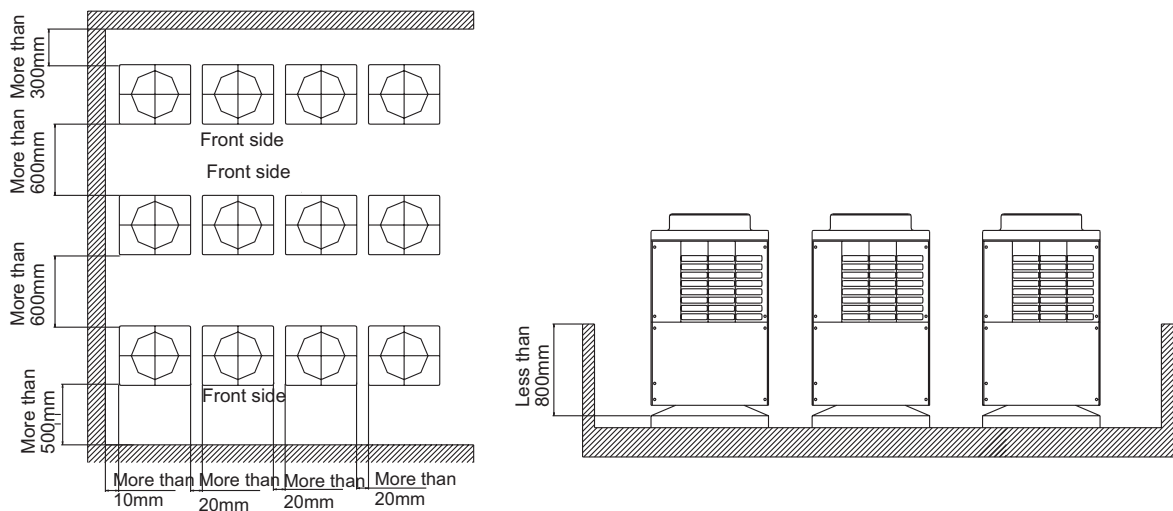

D. Piping

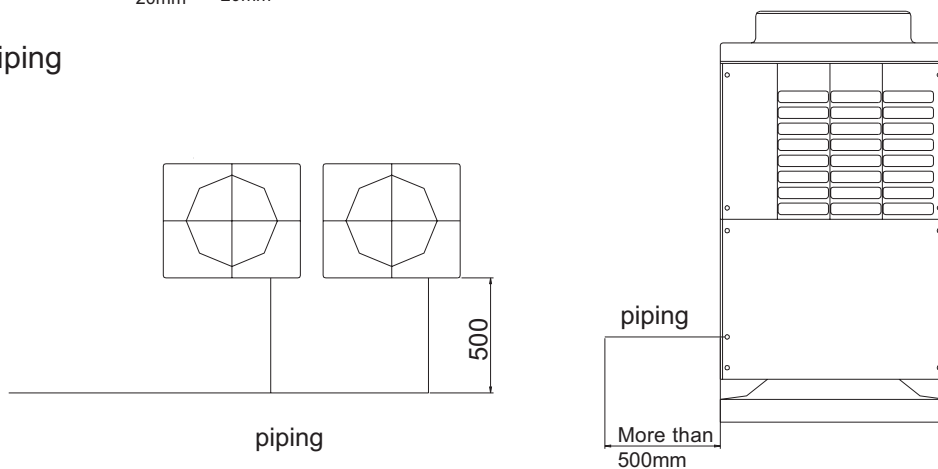



(2) Wall higher than the outdoor condenser

A. Place with air inlet hole

Notes:

A. Fan speed V_s at air inlet is 1.5m/s or below.

B. Air outlet height $HD=H-h$ and below 1m.

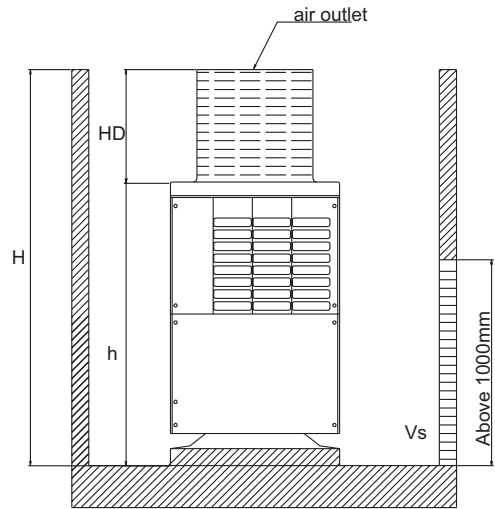
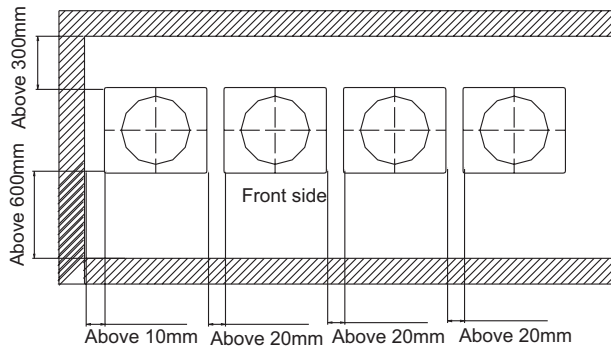

B. Place without air inlet hole

Notes:

A. Set a 500~1000mm bracket.

B. Air outlet height $HD=H-h$ and below 1m.

