

inspired living **Haier**



2009 General Catalogue Haier Solar Water Heater

2009 General Catalogue Haier Solar Water Heater

Haier Group

Address: No.1 Haier Road, Hi-tech Zone, Qingdao 266101 P.R. China

Contacts:

Tel: +86-532-8893-7672

Fax: +86-532-8893-7660

Website: www.haier.com

E-mail: hmrwo@haier.com

The products are distributed by





Haier Water Heater

Qingdao Economic and Technical Development Zone Haier Water Heater Co., Ltd.

Qingdao Economic and Technical Development Zone Haier Water Heater Co., Ltd., is one of the most rapidly-developed large scale backbone enterprises of haier group specializing in water heating products. Its production base located in Chongqing Qingdao and Wuhan has the annual production capacity of 5 million units. Its key equipments are from Germany, Italy, Japan, etc. And its important equipments are online and can be controlled remotely by computers.

Safety is the fundamental idea of Haier water heater. For many years, the company follows the tenet of high quality, high grade and high differentia and uses international advanced safety technologies to lead industrial trend and produce innovative products for clients. The company has established many international leading labs such as safety lab, shower lab and user simulative lab, etc. Its safety technologies, energy-saving technologies, inner tank technologies and intelligent control technologies are up to international advanced level. In 2001, Haier water heater was participated in stipulating national water heater energy-saving standard and in 2003 it was authorized to preside stipulating national water heater standards of safety, performance and specification of installation. In 2003, Haier's [PTO10] technology was adopted by IEC and it will become international standard. All of these fully show the powerful technologies of Haier water heater.

Haier water heater covers the most varieties and specifications of water heating products in this industry. It has over 300 varieties of 12 series, including electric water heater, gas water heater, solar water heater, and gas boiler, etc.

At present, energy crisis and environment pollution are increasingly serious, hence, energy saving and environment protection have become two main worldwide theme. Soalr energy is totally renewable green energy from the nature. Haier take the concept of "sincere forever", work on developping energy saving product, and advocate green consumption. Besides stepping in soalr water heater field, Haier develop photovoltaic products successively as solar central air-conditioner, solar hot water supply system, solar lawn lamp, solar street lamp, etc.



□ Assembly line □ Numerical control machinery □ Haier green energy product launching ceremony □ Haier solar energy Beijing experiencing center

Haier solar system - project sample



Beijing 2008 Olympic Game Qingdao Sailing Centre
Both for heating and chilling



Athlete Centre



Logistics Centre

Energy Saving:

Solar systems in Athlete Centre collect 456Mwh solar energy per year and in Logistics Centre collect 519Mwh per year. Two projects are totaled in 975Mwh per year.

CO₂ Emission Reduce:

These two projects reduce around 487500Kg CO₂ emission, equaling to the emission absorbency by 1 Ha. forest every year.

Profitability:

Whole project saves around 290 million USD during its 20 years service life.

Solar air-conditioning system for Beijing Olympic Village. Solar system have 1148m² collectors can supply cooling for 19500m² dinning hall. use gas heating as power backup to ensure 24 hours cooling.



Solar hot water system for Beijing Olympic Tennis Center, the system run automatically and can be controlled remotely. It supplies athletes hot water for shower and wash room, can save 97000KWH electric power per year, totally reduce 1200 tons CO₂ emission during its lifespan.



Flat Panel Collector

Horizontal Axis Parameter=(Tcollector-Tambient)/Isolar

Where Isolar is the solar intensity on the collector in watts/m². This chart allows a single curve to characterize collector performance. It shows the bigger of efficiency parameter, the better performance of the absorption; the smaller of the slope, collector have higher performance of insulation. Haier's collector have efficiency of 0.75 while national standard is >0.68, the slope of the curve is 5.0 while national standard is <6.0. This is parameter of Haier standard products, we can also produce better performance solar panel as customer's request.

New collector PTG2.0-2:

1. Aluminium Alloy- Silver casing material, stronger and much more beautiful.
2. 50mm insulation, 10 mm thicker than normal ones, better heat preservation performance.
3. Low iron toughened glass, stronger and higher transmittance rate.

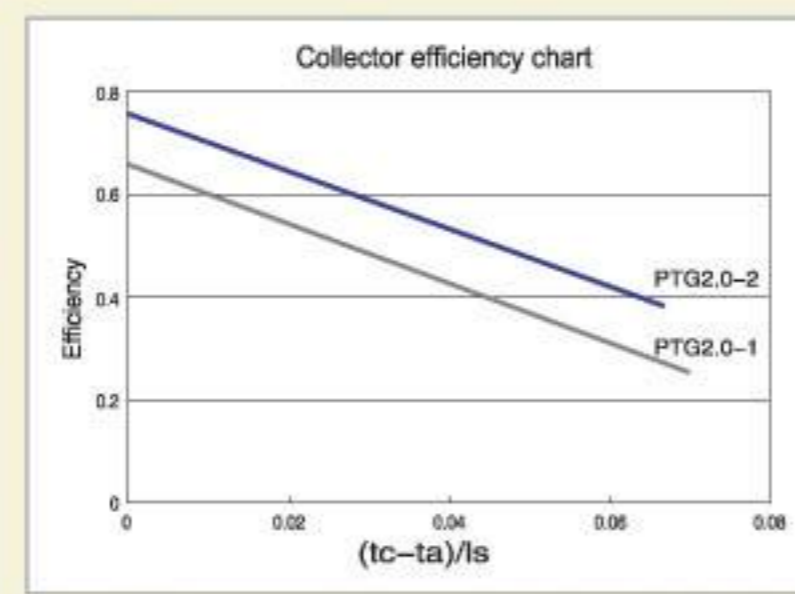

FLAT PANEL SOLAR COLLECTORS

Product	PTG 2.0-1	PTG 2.0-2
Dimensions (mm)	2000 X 1000 X 100	2002 X 1025 X 98
Panel Size (m ²)	2.0	2.1
Weight of collector (kg) - empty	42	42
N.o risers	8	8
Fluid capacity (litres)	1.8	1.8
Flux	Min. 10L/m ² h—Max.80L/m ² h	Min. 10L/m ² h—Max.80L/m ² h
Riser Dimensions (mm)	φ10*0.5	φ10*0.5
Header Dimensions (mm)	φ18*0.6	φ18*0.6
Media	Water/Liquid/Water and PG	Water/Liquid/Water and PG
Static Temperature	180°C solar radiation of 800W and ambient temperature of 30°C	180°C solar radiation of 800W and ambient temperature of 30°C
Maximum working pressure (Mpa)	0.6Mpa	0.6Mpa
Maximum test pressure (Mpa)	1.0 Mpa	1.0Mpa
Normal working pressure (Mpa)	0.4 Mpa	0.4 Mpa
Insulation type	Rock Wool	Rock Wool
Insulation density	56kg/m ³	56kg/m ³
Insulation thickness base (mm)	40	50
Insulation thickness density sides	56kg/m ³	56kg/m ³
Insulation thickness sides (mm)	20mm	20mm
Absorber plate coating type	TiN _{ox}	TiN _{ox}
Absorber surface area (Aperture) (square metres)	1.92	1.92
Absorber plate thickness (mm)	0.12mm	0.12mm
Absorber plate dimensions (mm)	962mm*1880mm*0.12mm	962mm*1880mm*0.12mm
Absorber Plate Material	Copper	Copper
Absorber Fin Spec (mm)	140mm	122mm
Absorber performance	0.95	0.95
Heat transfer coefficient	0.75	0.8
Heat loss coefficient	5.6W/m ² K	5.0W/m ² K
Reflectivity/ Emissivity performance	ε=4%±2%	ε=4%±2%
heat efficiency	η=0.68-5.6*(tc-tm)/Is	η=0.74-5.0*(tc-tm)/Is
Glazing Type	Toughened glass	Low iron toughened glass
Glazing thickness (mm)	4	4
Glazing Transmittance	>88%	>91%
Glazing iron content	<0.015%	<0.015%
Casing thickness (mm)	0.5mm	1.2mm
Frame material	colored steel plate	Aluminium Alloy- Silver
Inlet / outlet connections	DN15 Metal pipe	DN15 Metal pipe
max thermal expansion	3mm/ m	3mm/ m
Backing Sheet	colored steel plate 0.5mm	galvanized steel 0.4mm
Packing Dimensions	2070*1110*150mm	2070*1110*150mm
Qty in a 20' GP Container20	75	75
Qty in a 40' GP Container40	190	190

Flat Panel Solar Water Heater -- Open Loop



PJF1-100/150/200W

Features

1. Open loop system.
2. Flat panel split type, more harmonious to integrate the building.
3. High efficiency flat panel collector, long service life.
4. Enamel tank with magnesium rod for long-lasting protection against rust and corrosion.
5. Pressurized type, active system with pump, automatic water circle.
6. Solar controller.



Model	System type	Collector		Tank					
		collector type	area collector(m ²)	collector dimensions(mm)	inner tank size (L)	inner tank material	inner tank dia.(mm)	outer tank dia.(mm)	insulation (mm)
PJF1-100W	open loop	flat panel	2	2002*1025*98	100	enamel	φ412	φ492	40
PJF1-150W			4	2002*1025*98*2	150		φ412	φ492	50
PJF1-200W			4	2002*1025*98*2	200		φ412	φ492	50

Flat Panel Solar Water Heater -- Closed Loop



PJF2-100/150/200W

Features

1. Closed loop system with antifreeze protection, specially designed for cold area.
2. Flat panel split type, more harmonious to integrate with the building.
3. High efficiency flat panel collector, long service life.
4. Enamel tank with magnesium rod for long-lasting protection against rust and corrosion
5. With copper coil pipe exchanger
6. Pressurized type, active system with pump, automatical water circle.
7. With electric auxiliary heater
8. Solar station

Note

Antifreeze systems use special fluid to transfer heat from the collector to a heat exchanger in the storage unit. These systems are fully freezeprotected, prevent contamination of the hot water, and can operate in all climate conditions.

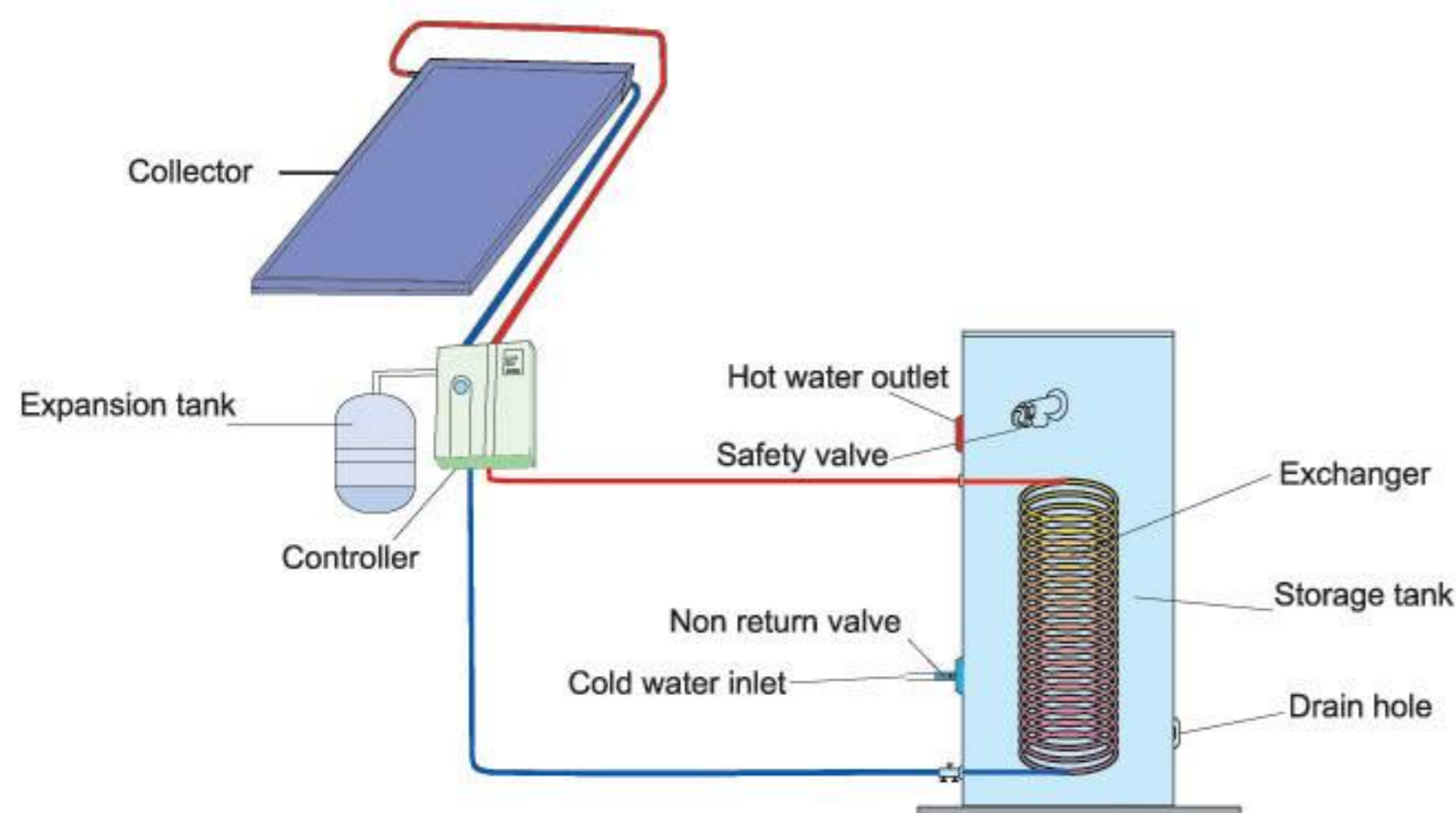

Model	System type	Collector		Tank					
		collector type	area collector(m ²)	collector dimensions(mm)	inner tank size (L)	inner tank material	inner tank dia.(mm)	outer tank dia.(mm)	insulation (mm)
PJF2-100W	closed loop	flat panel	2	2002*1025*98	100	enamel	∅ 412	∅ 492	40
PJF2-150W			4	2002*1025*98*2	150		∅ 412	∅ 492	50
PJF2-200W			4	2002*1025*98*2	200		∅ 412	∅ 492	50

Vacuum Tube Solar Water Heater



Features

1. Non-pressurized type, safe and long lasting.
2. High absorb efficiency glass vacuum tube, super heating efficiency and long service life.

Material

1. Inner tank: 0.5mm Stainless steel SUS-304.
2. Outer tank: 0.4mm Aluminum-zinc coated steel.
3. Vacuum tube: ∅58*1800/∅47*1500.
4. Frame: Thickened coated galvanized steel(1.5mm/1.2mm), strong and Anti-wind.
5. Insulation: 50mm polyurethane foaming, high heat preservation and energy saving.

Optional Kits

1. Controller with electric heating element, timer, thermal sensor and automatical cold water supply. (High class models)
2. Ordinary electric power backup with heating element and thermal sensor.

QBJ Series

Controller

Water temperature display Water level display

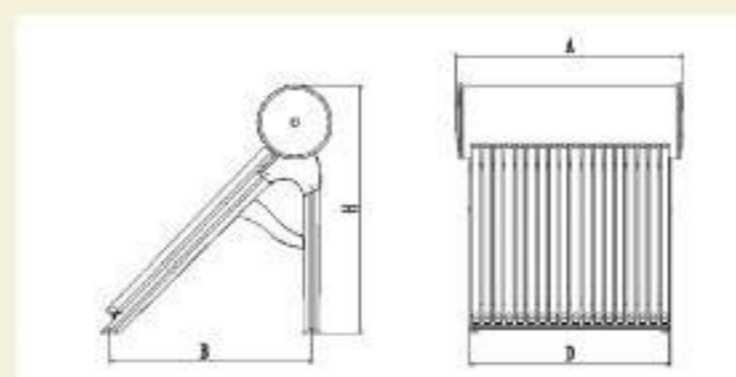

Automatic water supply

Pre-set time to supply water automatically.

Automatic heating

Pre-set time to heat water by electric power backup, supply hot water even in cloudy and rainy days.

Temperature display

With the thermal sensor inside display the water temperature inside the tank, avoid the hazard of being scalded by hot water.

Water level display

With water level sensor display the quantity of hot water inside the tank.

Error display

Display the error signal and warning when error occur the exception.

model	tube Nos.	tube spec	tank size	whole capacity	inner tank dia.	outer tank dia.	insulation	auxiliary heater	digital controller	collector area	dimensions(A*H*D*B)	loadability(40HC)
QBJ1-130A	14pcs	∅ 58*1800mm	130L	169L	∅ 382mm	∅ 482mm	50mm	0	no	1.79m ²	1325*1720*1137*1460	89
QBJ1-150A	16pcs	∅ 58*1800mm	150L	195L	∅ 382mm	∅ 482mm	50mm	0	no	2.07m ²	1485*1720*1297*1460	84
QBJ1-175A	19pcs	∅ 58*1800mm	175L	228L	∅ 382mm	∅ 482mm	50mm	0	no	2.48m ²	1725*1720*1537*1460	75
QBJ1-200A	22pcs	∅ 58*1800mm	200L	262L	∅ 382mm	∅ 482mm	50mm	0	no	2.90m ²	1965*1720*1777*1460	64
QBJ1-130A58E	14pcs	∅ 58*1800mm	130L	169L	∅ 382mm	∅ 482mm	50mm	1500W	yes	1.79m ²	1325*1720*1137*1460	89
QBJ1-150A58E	16pcs	∅ 58*1800mm	150L	195L	∅ 382mm	∅ 482mm	50mm	1500W	yes	2.07m ²	1485*1720*1297*1460	84
QBJ1-175A58E	19pcs	∅ 58*1800mm	175L	228L	∅ 382mm	∅ 482mm	50mm	1500W	yes	2.48m ²	1725*1720*1537*1460	75
QBJ1-200A58E	22pcs	∅ 58*1800mm	200L	262L	∅ 382mm	∅ 482mm	50mm	1500W	yes	2.90m ²	1965*1720*1777*1460	64
QBJ1-230A58E	25pcs	∅ 58*1800mm	230L	300L	∅ 382mm	∅ 482mm	50mm	1500W	yes	3.35m ²	2205*1720*2017*1460	59
QBJ1-270A58E	30pcs	∅ 58*1800mm	270L	354L	∅ 382mm	∅ 482mm	50mm	1500W	yes	4.03m ²	2605*1720*2417*1460	49
S75EHF/L	14pcs	∅ 47*1500mm	75L	96L	∅ 315mm	∅ 482mm	50mm	1500W	no	1.33m ²	1166*1457*1000*1351	130
S85EHF/L	16pcs	∅ 58*1800mm	85L	108L	∅ 315mm	∅ 482mm	50mm	1500W	no	1.52m ²	1306*1457*1140*1351	115
S110EHF/L	14pcs	∅ 58*1800mm	110L	150L	∅ 360mm	∅ 460mm	50mm	1500W	no	1.86m ²	1296*1710*1140*1590	95
S125EHF/L	16pcs	∅ 58*1800mm	125L	170L	∅ 360mm	∅ 460mm	50mm	1500W	no	2.13m ²	1456*1710*1300*1590	85
S150EHF/L	19pcs	∅ 58*1800mm	150L	205L	∅ 360mm	∅ 460mm	50mm	1500W	no	2.53m ²	1696*1710*1540*1590	75

Installation Sketch

Vacuum tube type parts list

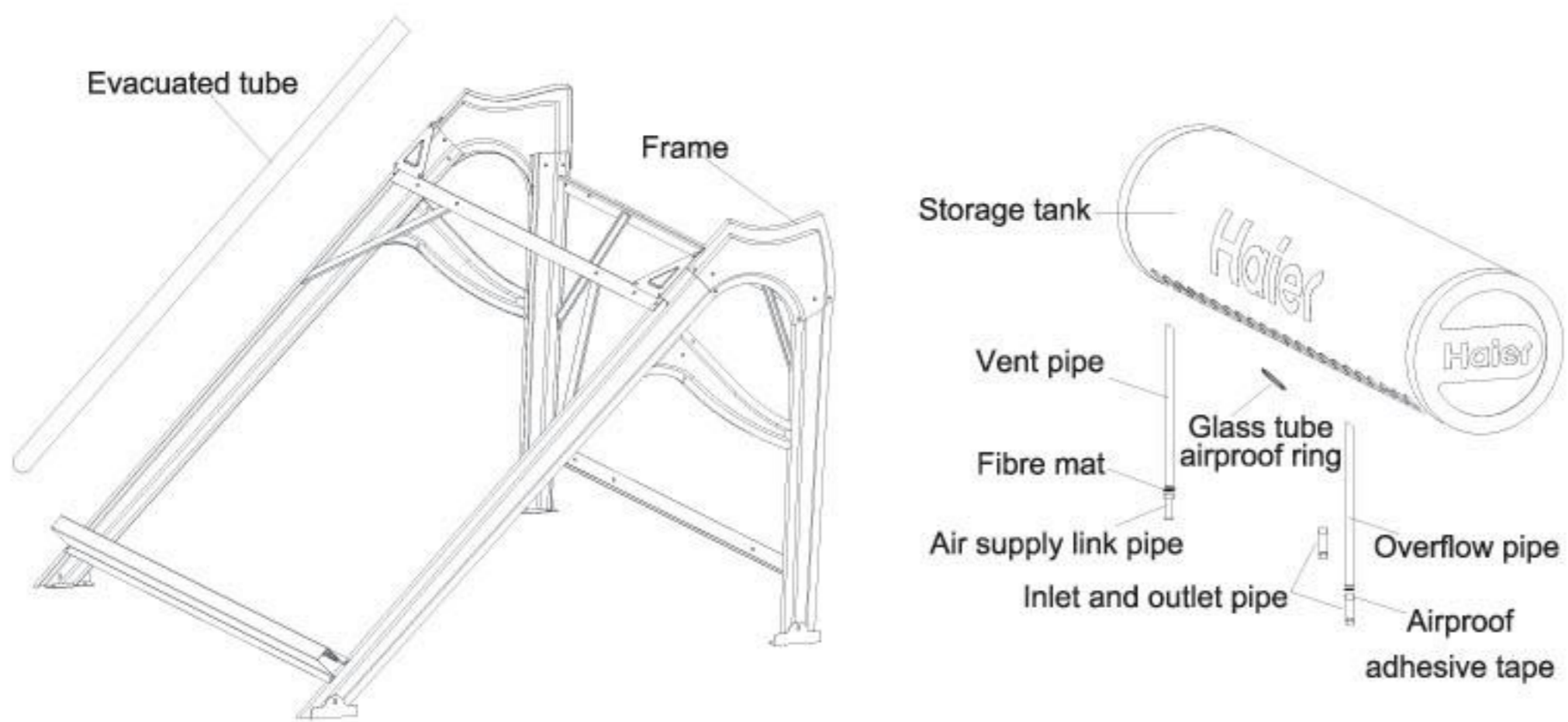

QBJ1 Series - without digital controller and auxiliary heater

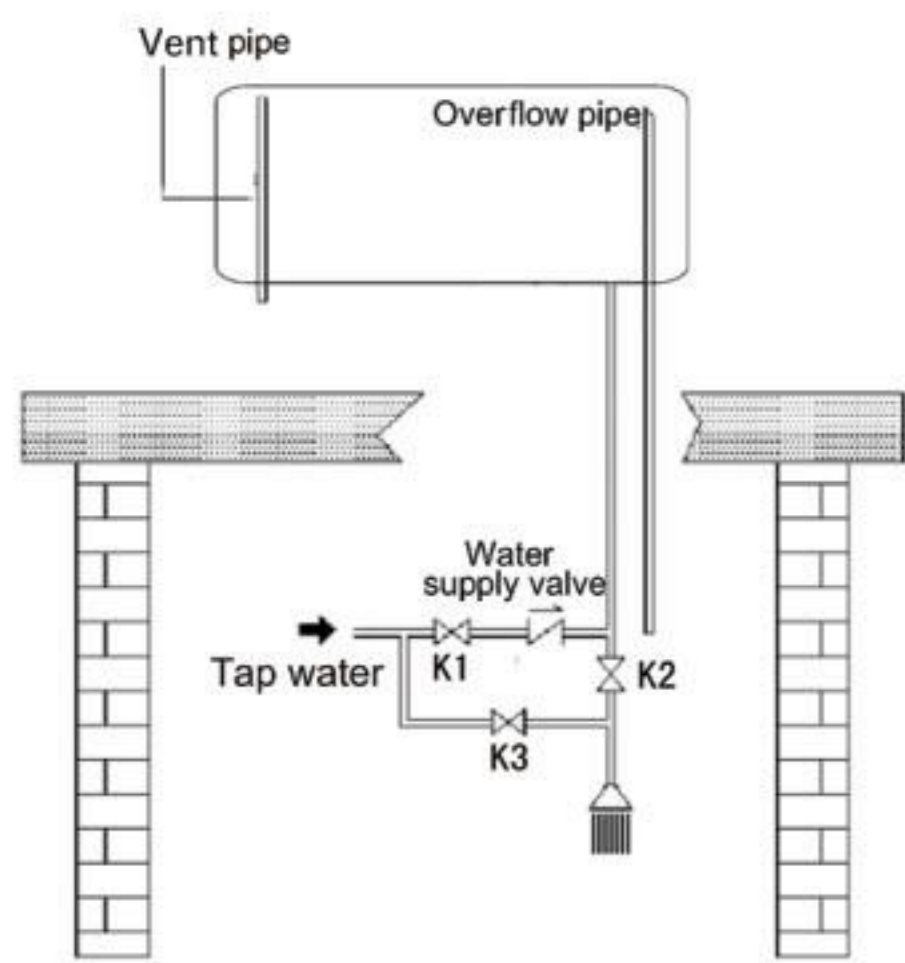

S Series - basic model

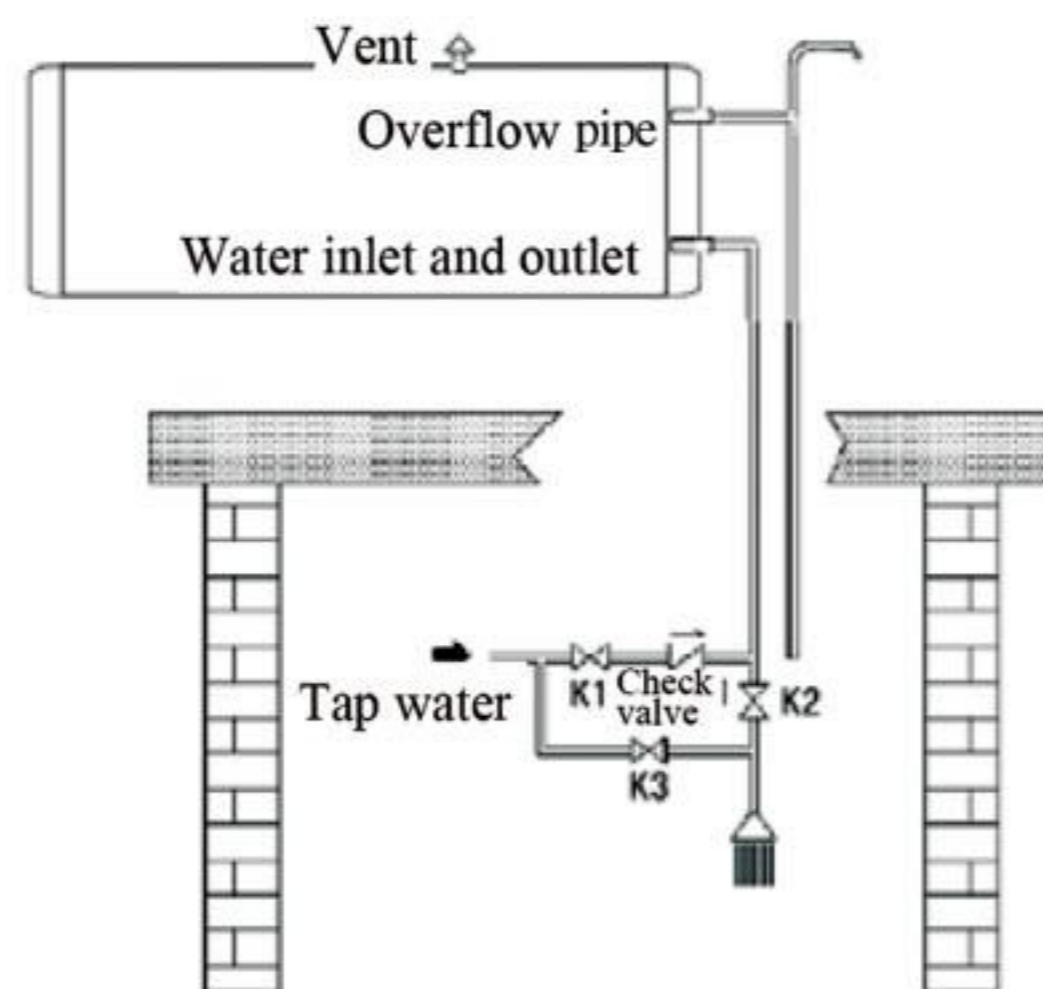

Installation Sketch

QBJ1 Series - with digital controller and auxiliary heater

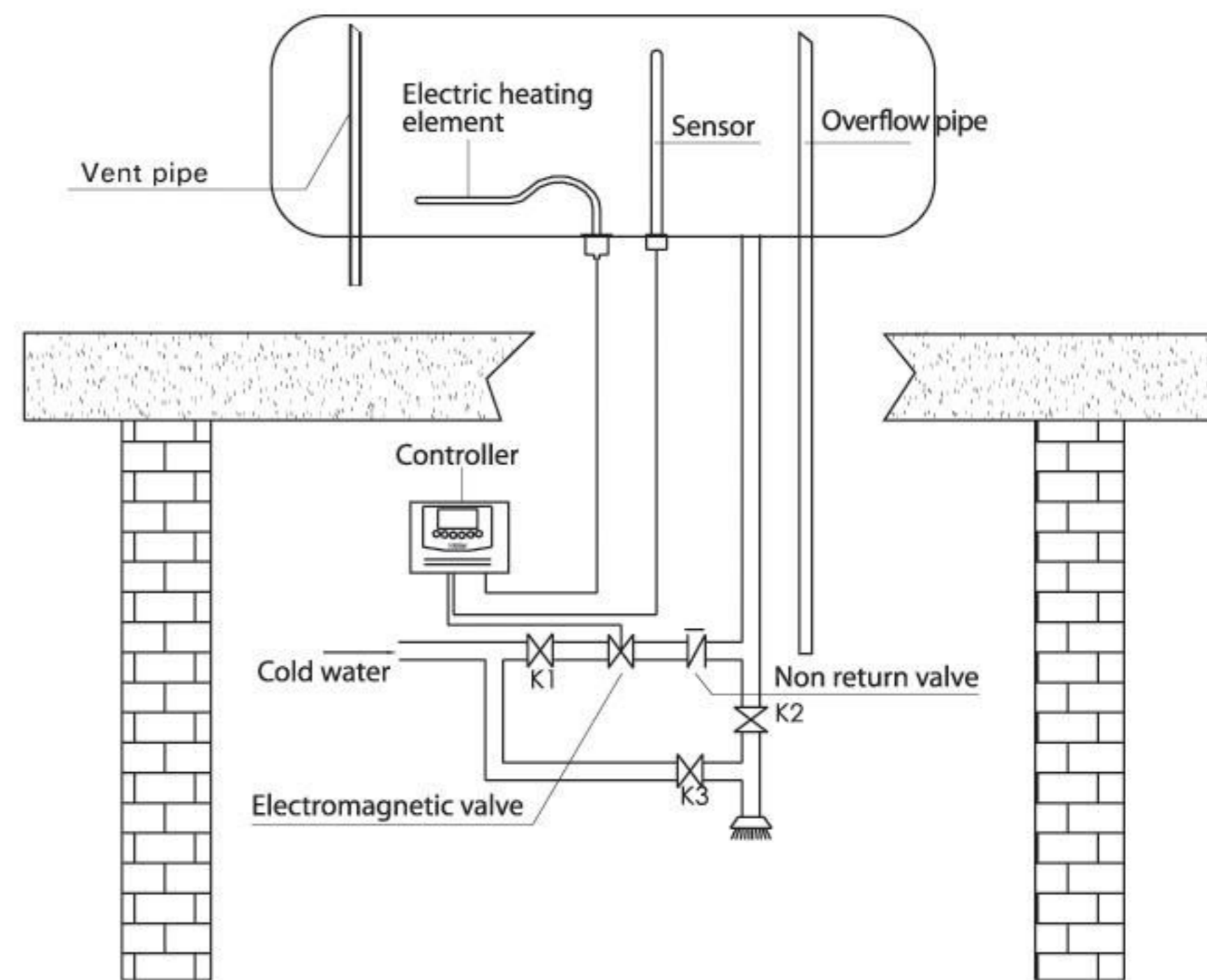

PJF1-120/150/200W

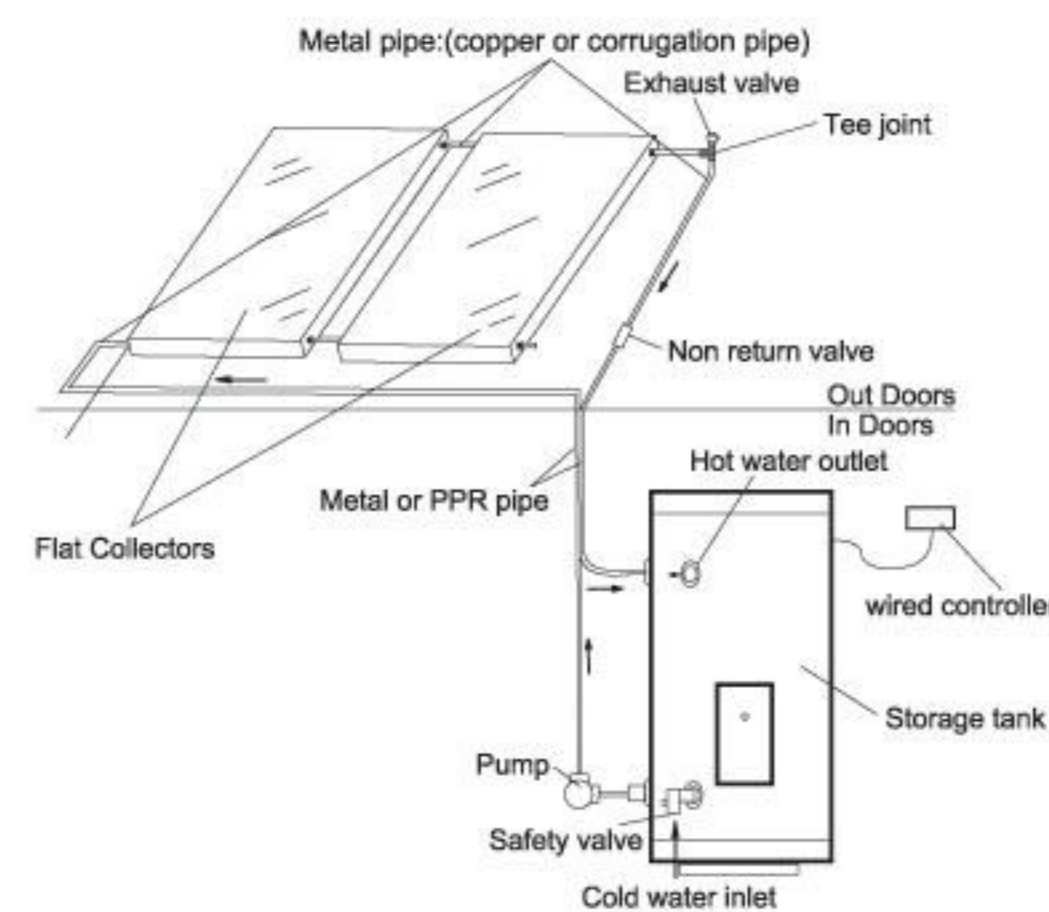

PJF2-100/150/200W

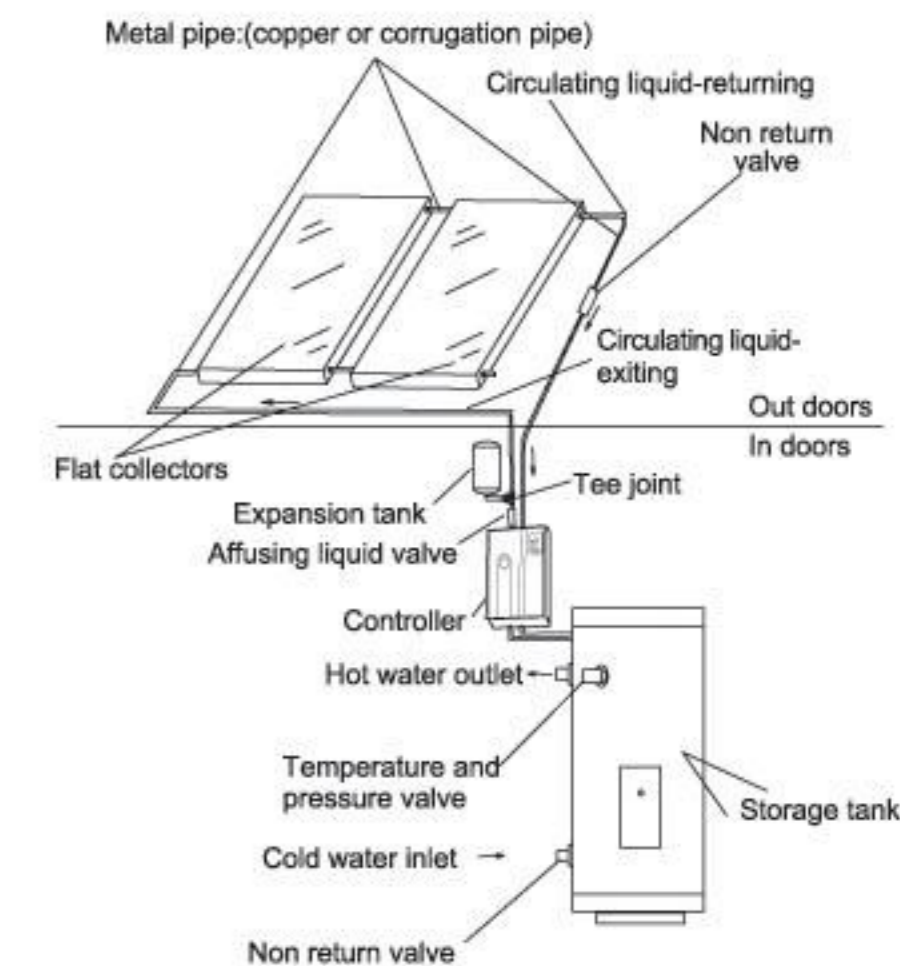

SOLAR HOT WATER SYSTEM — VILLA TYPE

1. System composition and working principle

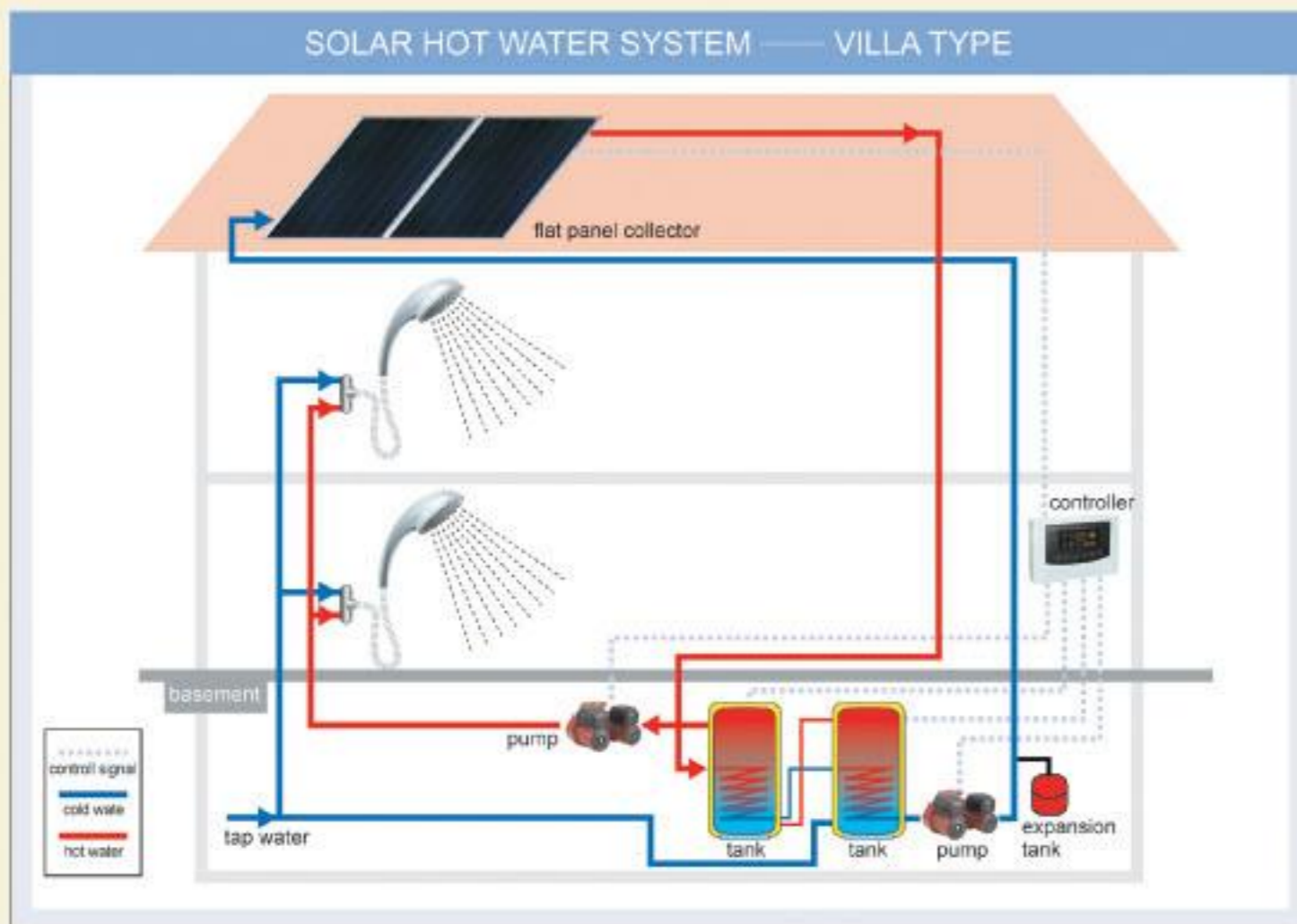

2. Features:

- A. Flat panel split type, more harmonious to integrate with the villa roof.
- B. Pressurized tank with coil exchanger and electric auxiliary heater inside.
- C. Closed loop system with perfect antifreeze performance.
- D. With pump and digital controller, automatic operation system.
- E. 30-50 years service life, save energy and protect environment.

3. Application: villas, small apartment buildings

SOLAR HOT WATER SYSTEM — BALCONY TYPE

1. System composition and working principle

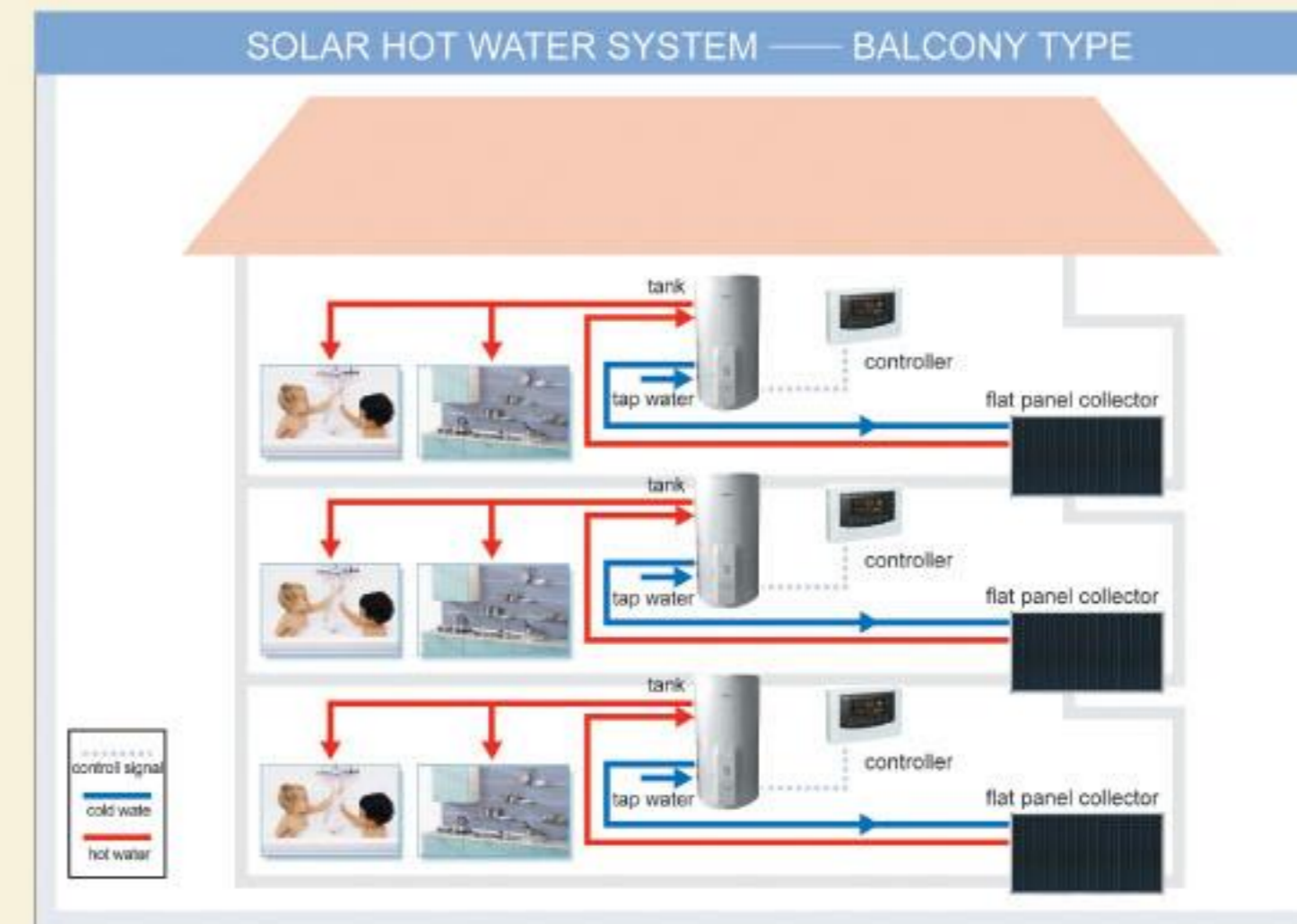

2. Features:

- A. Collectors on the balcony of the building, short transform pipeline, high efficiency.
- B. Tank with coil pipe exchanger and auxiliary heater inside.
- C. Automatic control system design, low maintenance cost.
- D. 30-50 years service life, save energy and protect environment.

3. Application: apartment building, tower building

CENTRALIZED SOLAR HOT WATER SYSTEM — FLAT PANEL TYPE

1. System composition and working principle

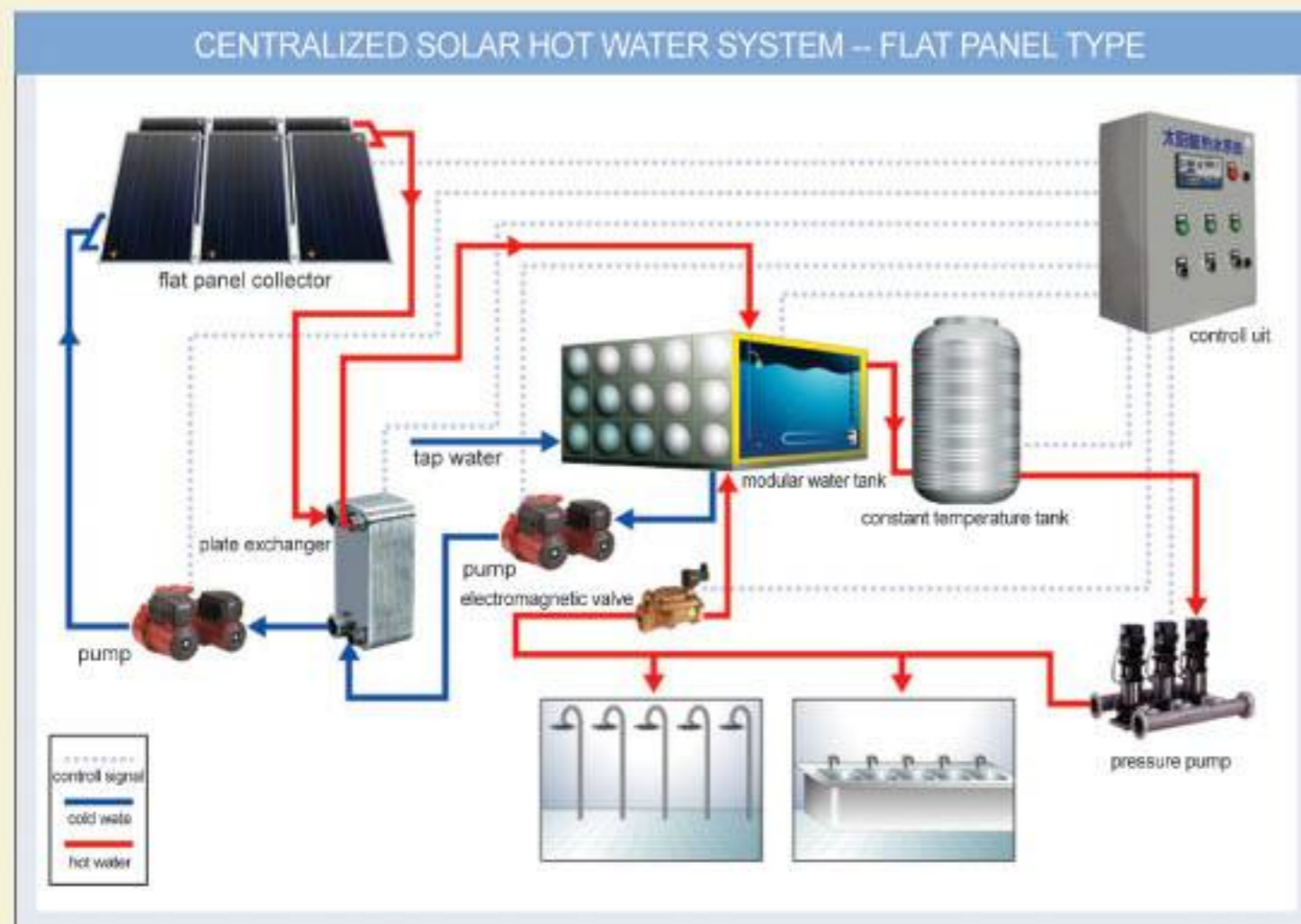
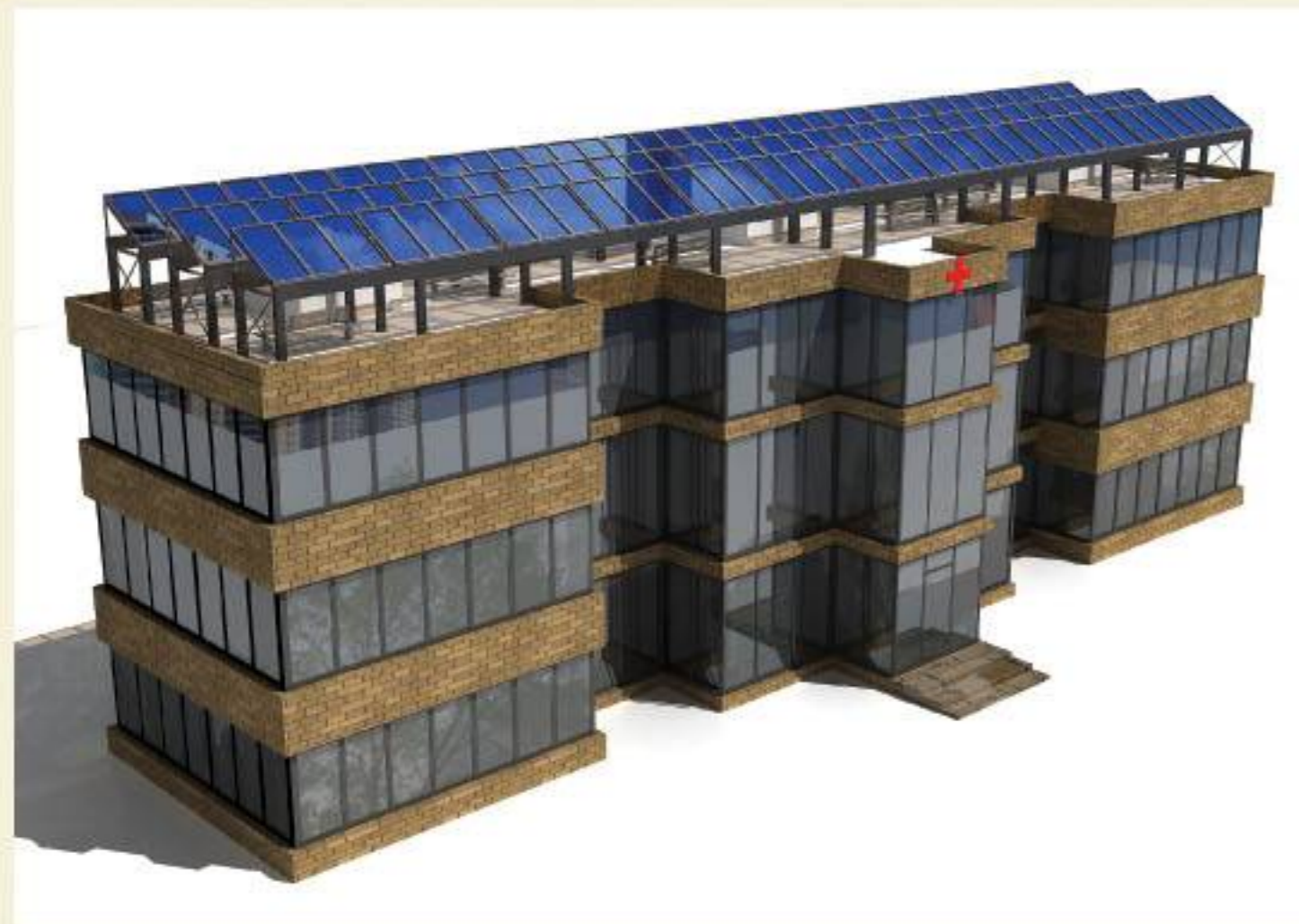

2. Features:

- A. Modular tank design, can meet large capacity needs of hot water.
- B. High efficiency plate exchanger.
- C. Flat panel collector, perfect integrate with the building roof.
- D. Combined with auxiliary heating system will achieve constant temperature hot water output.
- E. Automatical control system.
- F. 30-50 years service life, save energy and protect environment.
- G. Low maintenance cost.

3. Application: hospital, hotel, school, army ect. where need centralized hot water

CENTRALIZED SOLAR HOT WATER SYSTEM — VACUUM TUBE TYPE

1. System composition and working principle

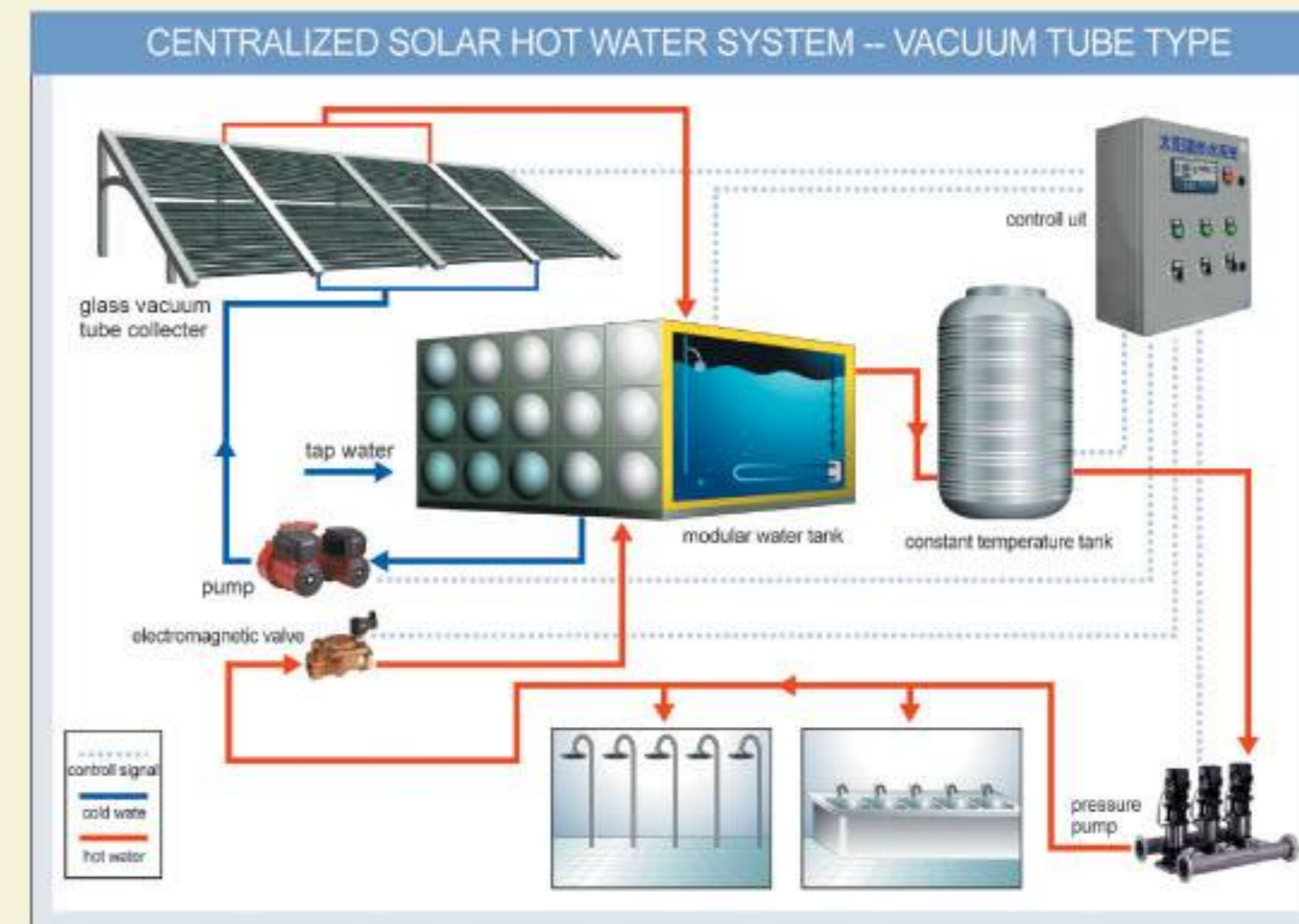

2. Features:

- A. Modular tank design, can meet large capacity needs of hot water.
- B. Vacuum tube collector, low system cost.
- C. Combined with auxiliary heating system will achieve constant temperature hot water output.
- D. Automatical control system

3. Application: factory, industry hot water

CENTRALIZED SOLAR HOT WATER SYSTEM — SEPRATE CHARGE

1. System composition and working principle

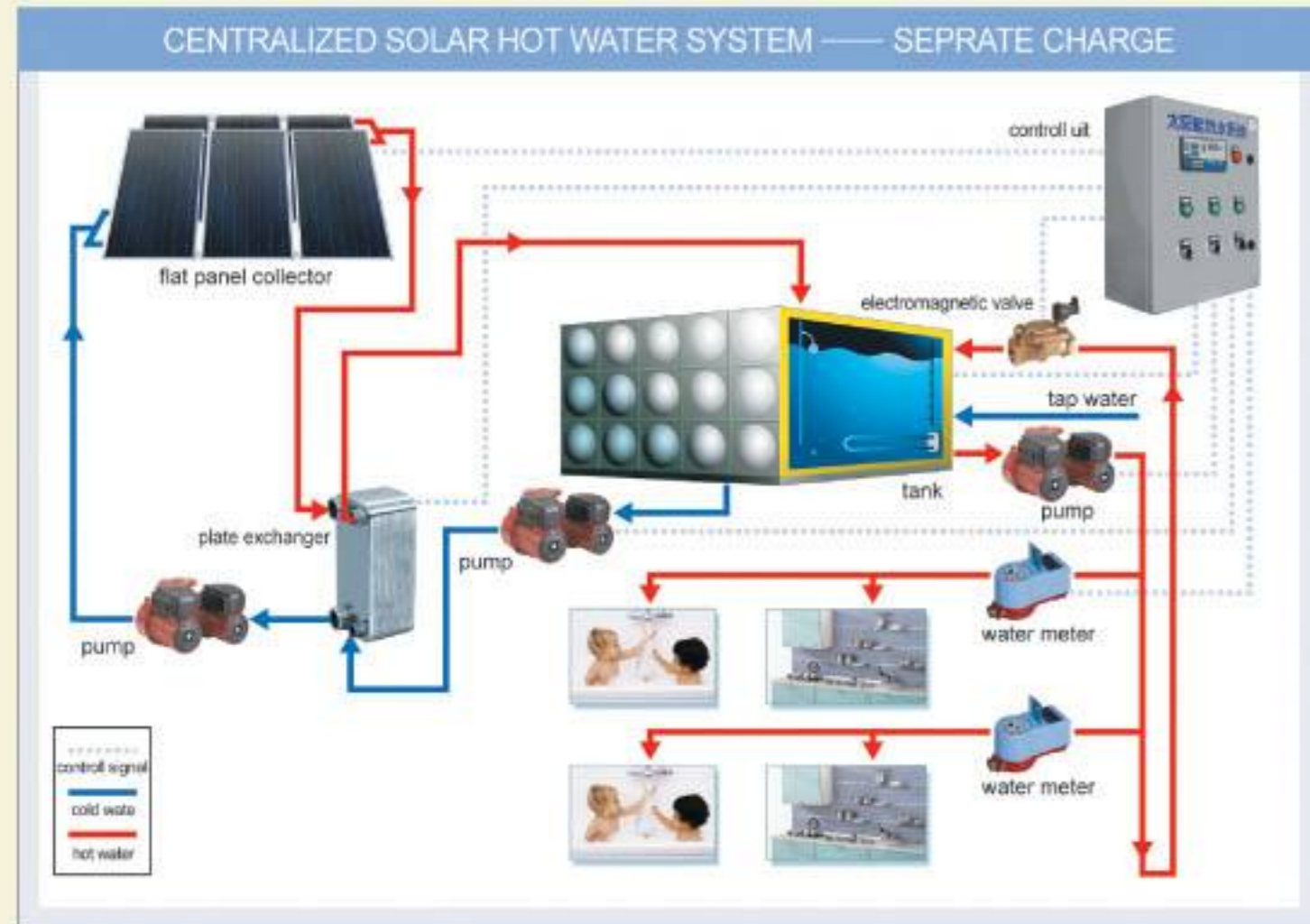

2. Features:

- A. Modular tank design, can meet large capacity needs of hot water.
- B. Heat water with Plate exchanger
- C. Flat panel collector, perfect integrate with the building.
- D. Combined with auxiliary heating system will achieve constant temperature hot water output.
- E. Automatical control system design, low maintenance cost.
- F. 30-50 years service life, save energy and protect environment.
- G. Each apartment has hot water meter to calculate cost separately.

3. Application: apartment building, tower building

CENTRALIZED SOLAR HOT WATER SYSTEM — SEPRATE TANK

1. System composition and working principle

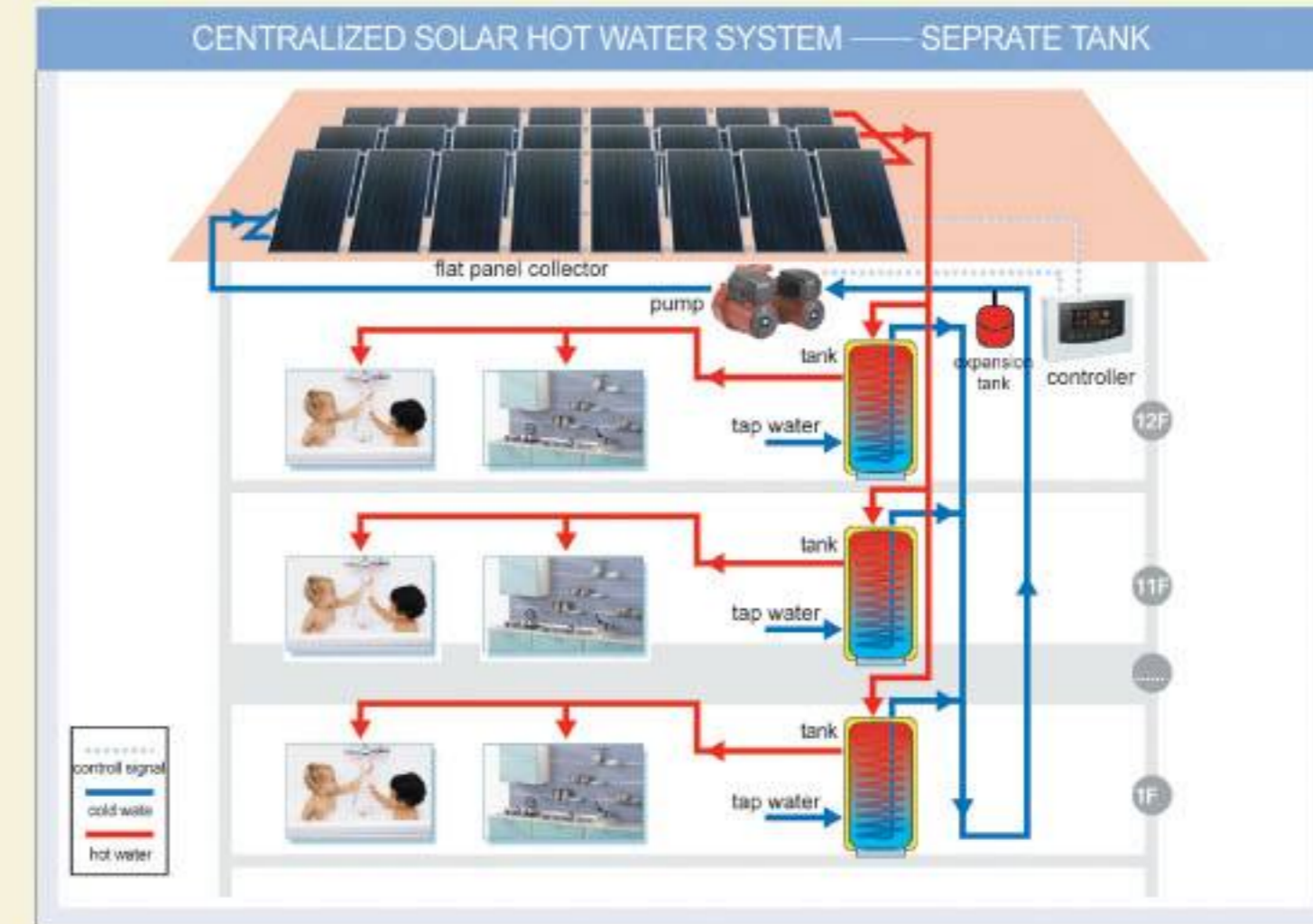

2. Features:

- A. Collectors on the roof of the building, each apartment has a separate tank.
- B. Tank with coil pipe exchanger and auxiliary heater inside.
- C. Automatical control system design, low maintenance cost.
- D. 30-50 years service life, save energy and protect environment.

3. Application: apartment building, tower building